

Garrard

Service manual for Garrard Model SP25 MkIII



Model SP25 Mk III



Module SP25 Mk III

Single record playing unit

(Also other models in the Garrard 'Autoslim' mechanism range, including Model SP25 Mk IV)

Garrard
Sales Service Department
Kembrey Street
Swindon Wiltshire England
Telephone: Swindon (0793) 6211
Telex: 44180

contents

| | |
|------------------------------------|-------|
| General information | 3 |
| Installation | 4 |
| Wiring | 5 |
| Fitting pickup cartridge | 6 |
| Installation adjustments | 6 |
| Operating instructions | 7 |
| Maintenance | 8 |
| Exploded view and spare parts list | 10 11 |
| Service adjustments | 12 |
| Dismantling | 13 |
| Fault charts | 14 |

diagrams

| | |
|---|------------|
| Fitting counterbalance weight | diagram 1 |
| Transit screw positions | diagram 2 |
| Parking peg assembly | diagram 3 |
| Voltage changeover block connections | diagram 4 |
| Pickup tag strip connections | diagram 5 |
| Phono socket connections | diagram 6 |
| Pickup cartridge connections | diagram 7 |
| Stylus force dial and bias compensator | diagram 8 |
| SP25 Mk III, general view | diagram 9 |
| Turntable clip removal | diagram 10 |
| SP25 Mk III, turntable removed | diagram 11 |
| SP25 Mk III, underside view | diagram 12 |
| Pickup arm adjustments | diagram 13 |
| Intermediate wheel height adjustments | diagram 14 |
| Plug-in motor connections | diagram 15 |
| Pickup arm overload spring location | diagram 16 |
| Switch off lever and selector mechanism | diagram 17 |
| Selector actuating lever location | diagram 18 |
| Lead clamps | diagram 19 |
| Friction link | diagram 20 |
| Pickup lifting mechanism | diagram 21 |

general information

The Garrard SP25 Mk III continues the line of models in which a proven record playing mechanism has been adapted to the specialized requirements of a single record playing unit. To this end a number of refinements and features are included in this model, all of which add to the appeal which has made the SP25 Series the most popular choice in its class.

Notably, an improved damped cueing system is incorporated and as an alternative to cueing, automatic play of a single record is now possible. Standard manual play and Reject facility are of course, still featured. Other refinements include a fully adjustable pickup arm bias compensator and the versatile Garrard Type C2 slide-in cartridge carrier which facilitates the inspection and replacement of stylus or cartridge. The tubular aluminium pickup arm with its precision ball bearing pivots, resiliently mounted counterbalance weight and calibrated stylus force dial, remains characteristic of this series of units and the SP25 Mk III is powered by a Garrard motor of well tried reliability.

Special attention has been paid to the relationship between the turntable and pickup arm, so that the vertical tracking geometry for the majority of pickup cartridges is correct when playing the single record. After playing a record, the pickup lifts, returns to its rest and the unit switches off automatically.

Model SP25 Mk III is normally supplied as a combined high and low voltage range unit, which will run on either 110/125V or 220/240V AC according to the setting of the links in the changeover block. The unit will run on 50Hz or 60Hz frequency, according to the type of motor pulley fitted.

The unit plays any record up to 12in diameter at three standard speeds of $33\frac{1}{3}$ rev/min, 45 rev/min or 78 rev/min.

Before connecting the unit, make sure that the power supply is of the range to which the motor is set. If the pickup circuit of the unit is connected to an amplifier whose wiring is not isolated from the power supply, isolating components must be incorporated in the pickup circuit, otherwise the pickup circuit can become live. Always disconnect the power supply and protect the stylus before servicing a unit.

Garrard record playing equipment is made to play records complying with B.S.1928/1965 and I.E.C. Publication 98, also other similar standards.

If you require spare parts, please quote the code number for the Garrard unit, unless a full description can be given. The code number for Model SP25 Mk III is 74750 plus its following three figure stroke number over stamped on its inspection label attached to the underside of the unit.

Module version

Besides being marketed as a deck only this series of units is also supplied in module form, complete with module base, hinged lift-off moulded cover and connecting leads. The module form is usually supplied for one voltage range only with a three-core or two-core mains lead already connected. A phono lead with a five pin DIN plug is normally fitted and the module may be supplied with or without pickup cartridge.

Later units in this series

Model SP25 Mk III is developed from the well-known Garrard 'Autoslim' mechanism and this service manual provides much of the information which may be of use with both earlier and later models in this series. Exploded view and parts lists supplements for such models may be used with this manual. Note that the SP25 Mk IV is similar to the Mk III, but has restyled decor and pickup head, plug-in Synchro-Lab motor, also new turntable spindle and main bearings, and close-fit motor pulley. Model 35SB is belt-drive development from this mechanism. The exploded view supplement for Model 35SB includes information on the mechanism differences for this latter model.

installation

Unpacking

When unpacking a unit, withdraw it and its polyfoam pack from the carton as instructed on the carton flap. Never lift the unit by its pickup arm. Carefully remove all packing materials which may include wire ties, rubber bands, plastic bags and cardboard fitments. Accessories are found in the rear cavities of the polyfoam pack.

Cabinet space

Model SP25 Mk III is 14 $\frac{3}{4}$ in (374.5mm) wide by 12 $\frac{1}{2}$ in (317.5mm) front to rear by 2 $\frac{7}{8}$ in (73mm) above and 2 $\frac{1}{8}$ in (54mm) below the lower edge of the unit plate. Although the template (supplied with the unit) illustrates a minimum recommended mounting board size, this will depend on the particular cabinet and a general rule is to allow at least $\frac{1}{2}$ in (12mm) clearance to the dimensions given here, in order to give $\frac{1}{4}$ in (6mm) all round the edge of the unit and $\frac{1}{2}$ in (12mm) above and below for the unit to float freely on its mountings. These clearances also allow for the unit to be clamped for transit.

Additional clearance may be required around the unit according to the design of the cabinet or case. If necessary, allow clearance for operating the controls, record handling and 12in records.

Fitting

- 1 Cut out the mounting board to the template (fix the template to the board with adhesive tape and mark through with a sharp point). If the board is more than $\frac{1}{2}$ in (12mm) thick the transit holes will need recessing to 1 $\frac{1}{8}$ in (28.5mm) diameter from underneath to reduce the effective board thickness to $\frac{1}{2}$ in (12mm).
- 2 Attach earth, power supply and audio leads to the unit, noting that they must not restrict the movement of the mechanism (see 'Wiring').

- 3 Assemble the unit to the board with transit screws turned right down and locking clips set vertical. Locate the foam damped mounting springs in their recesses in the board and make sure any attached leads go through the cut-out.

- 4 When the unit is in place, press it down on its springs, then turn the transit screw locking clips horizontal as in diagram 2a.

(Note: When transporting the unit, the transit screws should always be turned counterclockwise to clamp the unit against the board as in diagram 2b.)

- 5 Fit the counterbalance weight, found in a cavity of the polyfoam pack, to the rear of the pickup arm as shown in diagram 1, then (assuming a pickup cartridge is fitted) set stylus force and bias compensator as described under 'Installation Adjustments'.

- 6 Fit the record spindle in its turntable centre location.

- 7 As a check on the mechanism revolve the turntable slowly clockwise by hand. Use an old record for setting up purposes, and with power supply off, move the operating control to 'Auto' to see that the unit responds as described under 'Operating Instructions'.

- 8 Reset pickup arm adjustments if necessary (see 'Adjustments' section).

- 9 If required, drill an $\frac{1}{8}$ in (3mm) hole in the cabinet at a convenient place and assemble the kit of parts supplied as a parking peg for the 45 rev/min adaptor. See diagram 3. (Kit discontinued on later models).

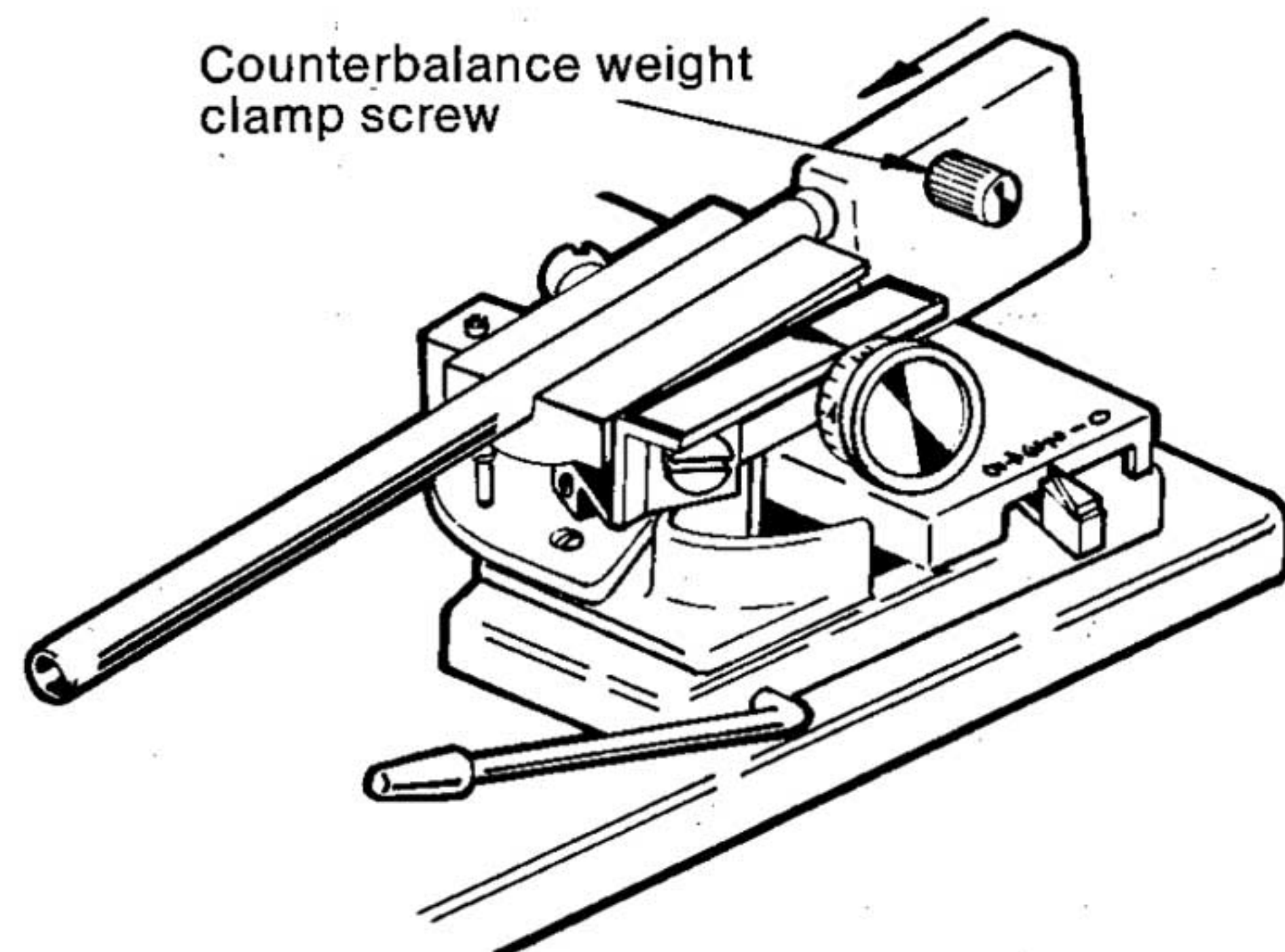
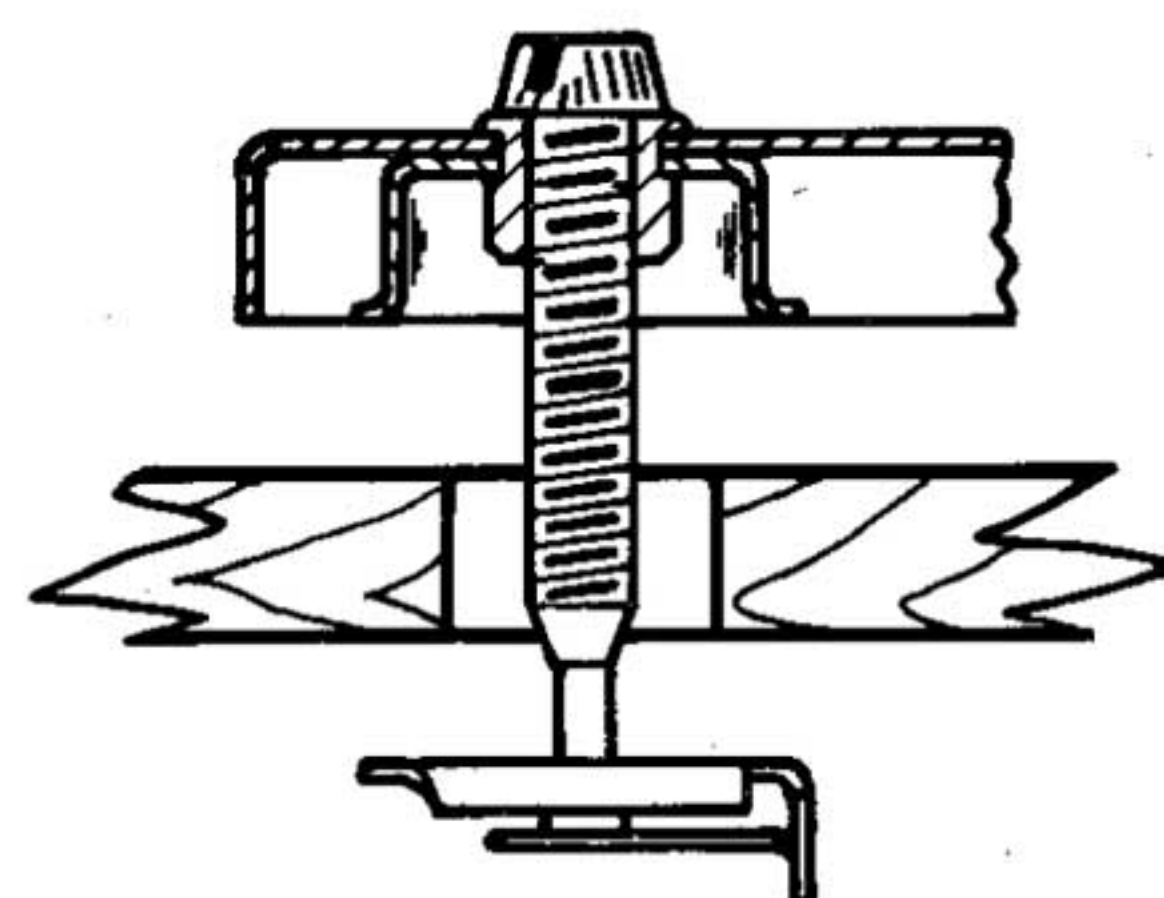

diagram 1

Transit screw details

Clip must be vertical when assembling unit to mounting board

(a) Transit screw in playing position



(b) Transit screw in transport position

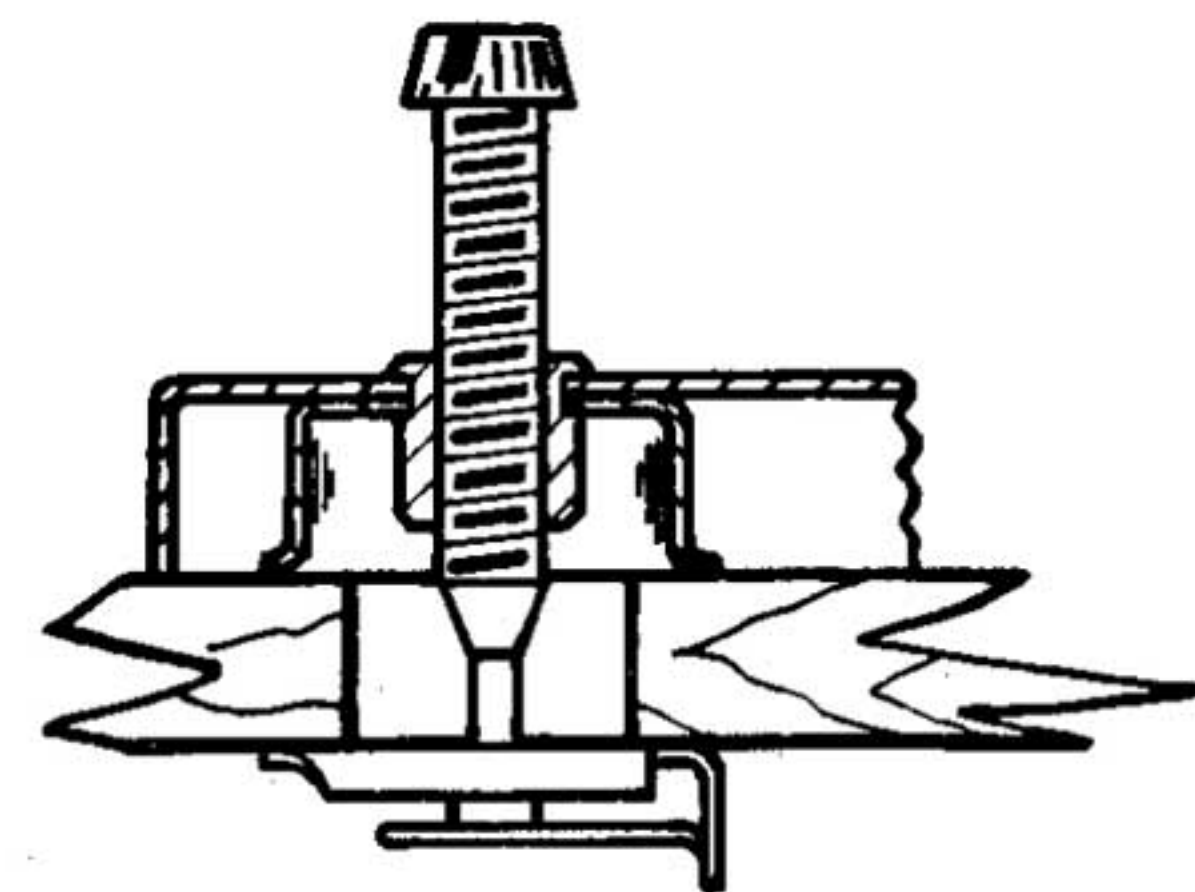

diagram 2

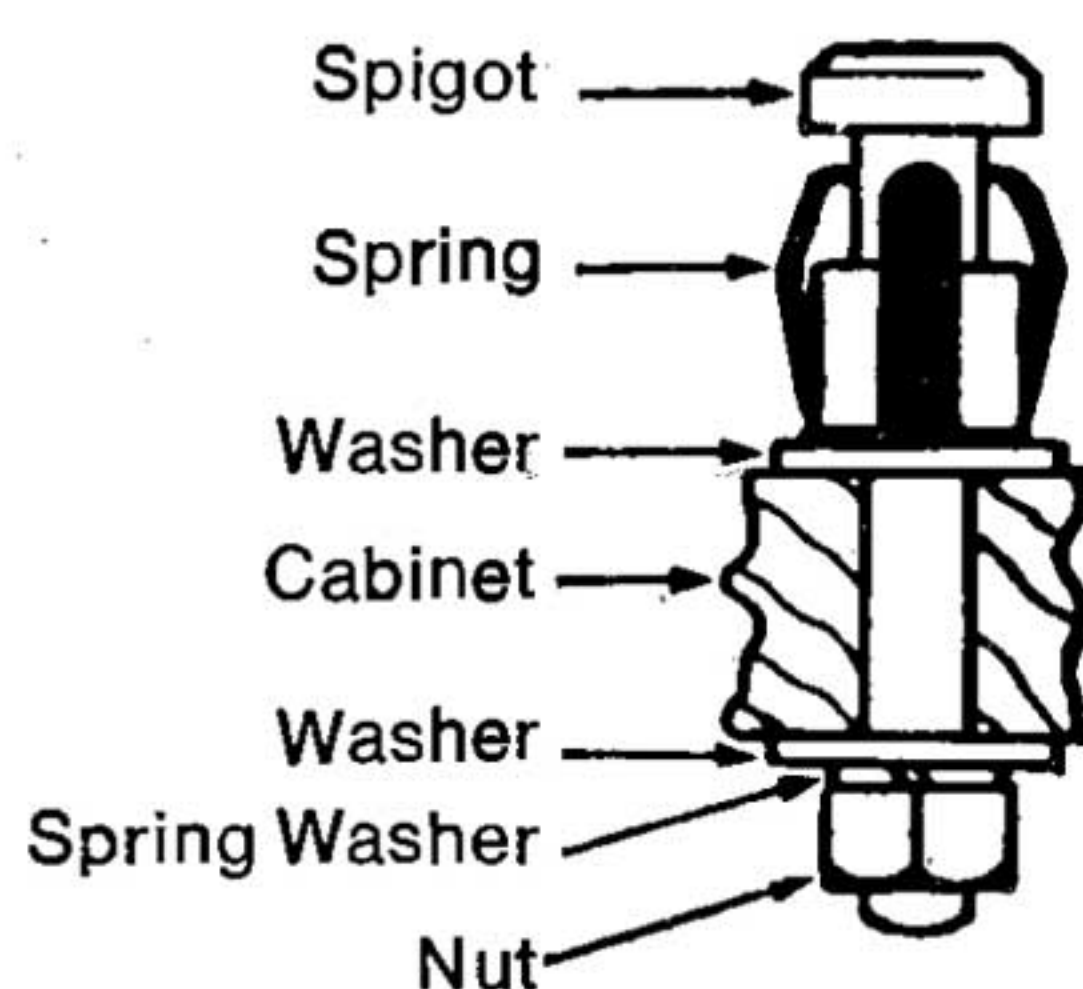

diagram 3

wiring

Power supply connections

Power supply leads complying with the international standard colour coding should be used on these units as follows:

| | | |
|------------------|---|--------------------------|
| Green and Yellow | — | Earth (formerly Green) |
| Blue | — | Neutral (formerly Black) |
| Brown | — | Live (formerly Red) |

Connect an earth lead from the screw terminal on the side of the voltage changeover block to a good earthing point.

Attach a flexible power supply lead from the terminals inside the voltage changeover block to the power supply. Make sure that the 'live' lead (brown) goes from the terminal marked 'L' to the 'live' pin of the power supply plug and the 'neutral' lead (blue) goes from the terminal marked 'N' to the 'neutral' pin. See diagram 4.

Model SP25 Mk III is normally supplied as a combined high and low voltage range model – nominally 110/125V or 220/240V AC, according to the setting of the links in the changeover block. Make sure the links are set to suit the supply voltage as shown in diagram 4. The unit will run on 50Hz or 60Hz frequency according to the type of motor pulley fitted (see 'Speed' paragraph under 'Adjustments').

If the unit is a low voltage model for 110/125V AC only, a line cord socket will be fitted in place of the voltage changeover block and a line cord plug should be connected from the unit to the power supply; also connect the unit to an earthing point.

The module version of these units is usually supplied already fitted with a 3-core mains lead to the above colour code. When a 2-core mains lead is already fitted note that an earth link is provided as chassis earthing only between the phono socket and the right channel earth lead to the

amplifier. If an earth lead is added when a 2-core mains lead is already fitted, it may be necessary to disconnect the earth link on the phono socket in order to avoid hum.

Audio connections

Connect screened leads from the pickup terminal tag strip (if fitted) to the amplifier (see diagram 5). If the unit is to be connected to an amplifier whose wiring is not isolated from the power supply, isolating components must be incorporated in its pickup circuit.

On some units pickup leads may terminate at a phono socket or muting switch instead of a tag strip, but the same pickup lead colour coding applies, namely:

| | | |
|-----------------|---|----------------------|
| Red | — | Right channel signal |
| Green | — | Right channel ground |
| White | — | Left channel signal |
| Black (or Blue) | — | Left channel ground |

On units to which a phono socket is fitted, connect phono leads from left and right channel sockets to the amplifier. See diagram 6. When a stereo pickup is used with a mono amplifier, parallel the right and left channels – if a 'mono' switch is not incorporated in the amplifier, connect the right channel signal terminal to the left channel signal terminal, and the right channel ground terminal to the left channel ground terminal.

The module version of these units is usually supplied already fitted with a five pin DIN plug and connecting lead to the phono socket beneath the unit. The DIN plug connections are:

- Pin 3 – Left channel signal
- Pin 5 – Right channel signal
- Pin 2 – Common ground (both lead screens)

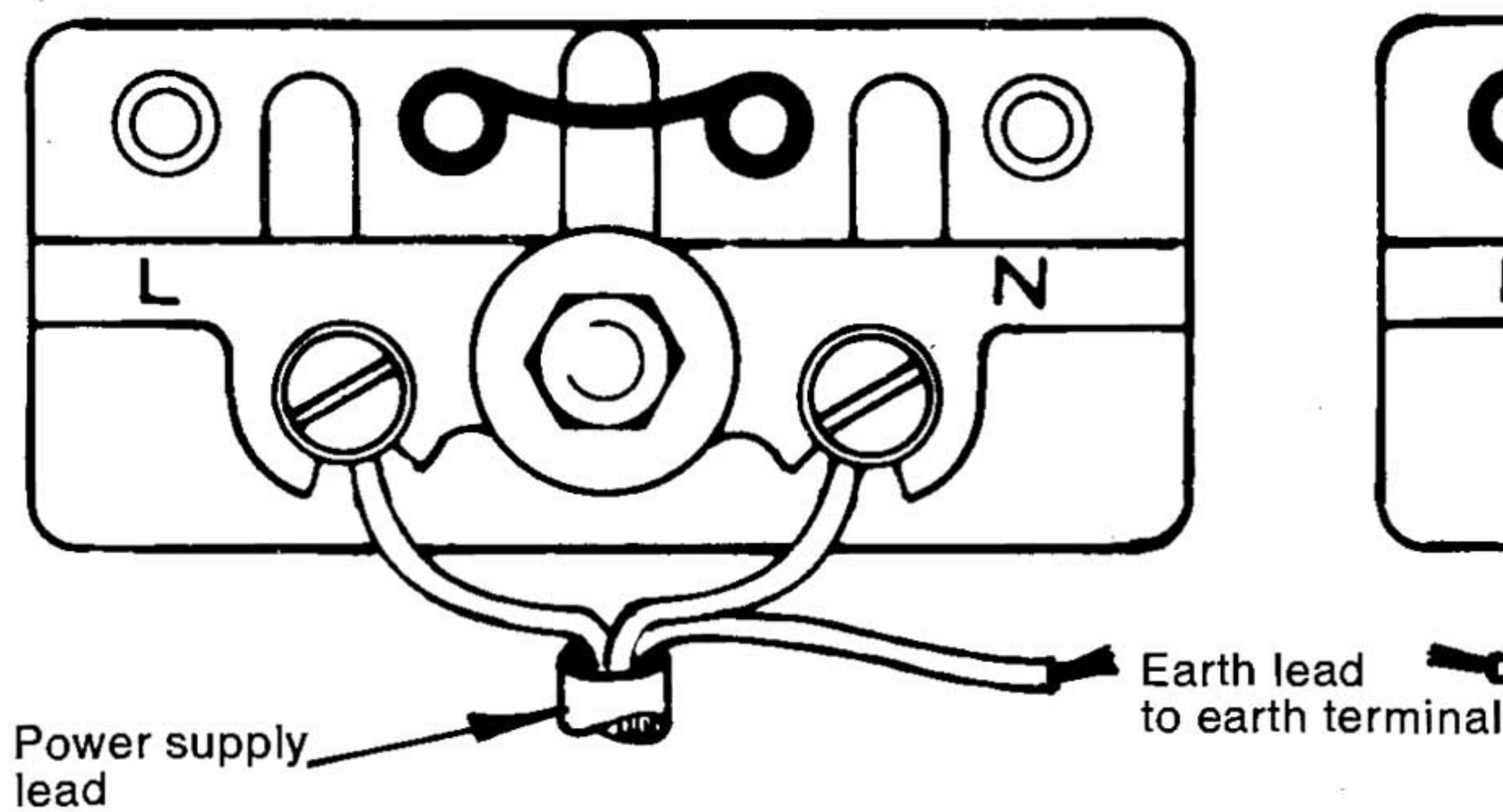

Both links set for nominal 220/240 voltage range

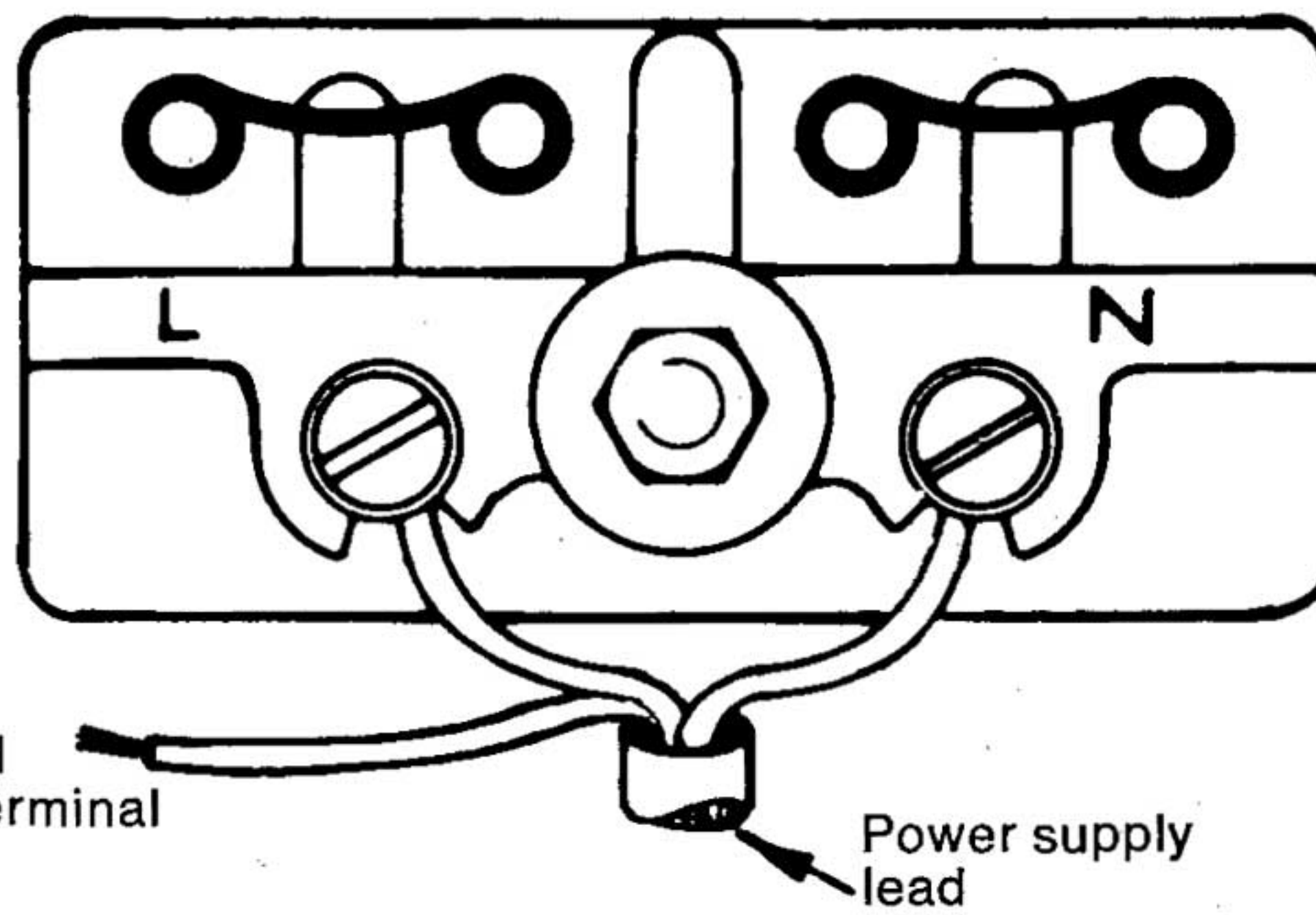

Links set for nominal 110/125 voltage range

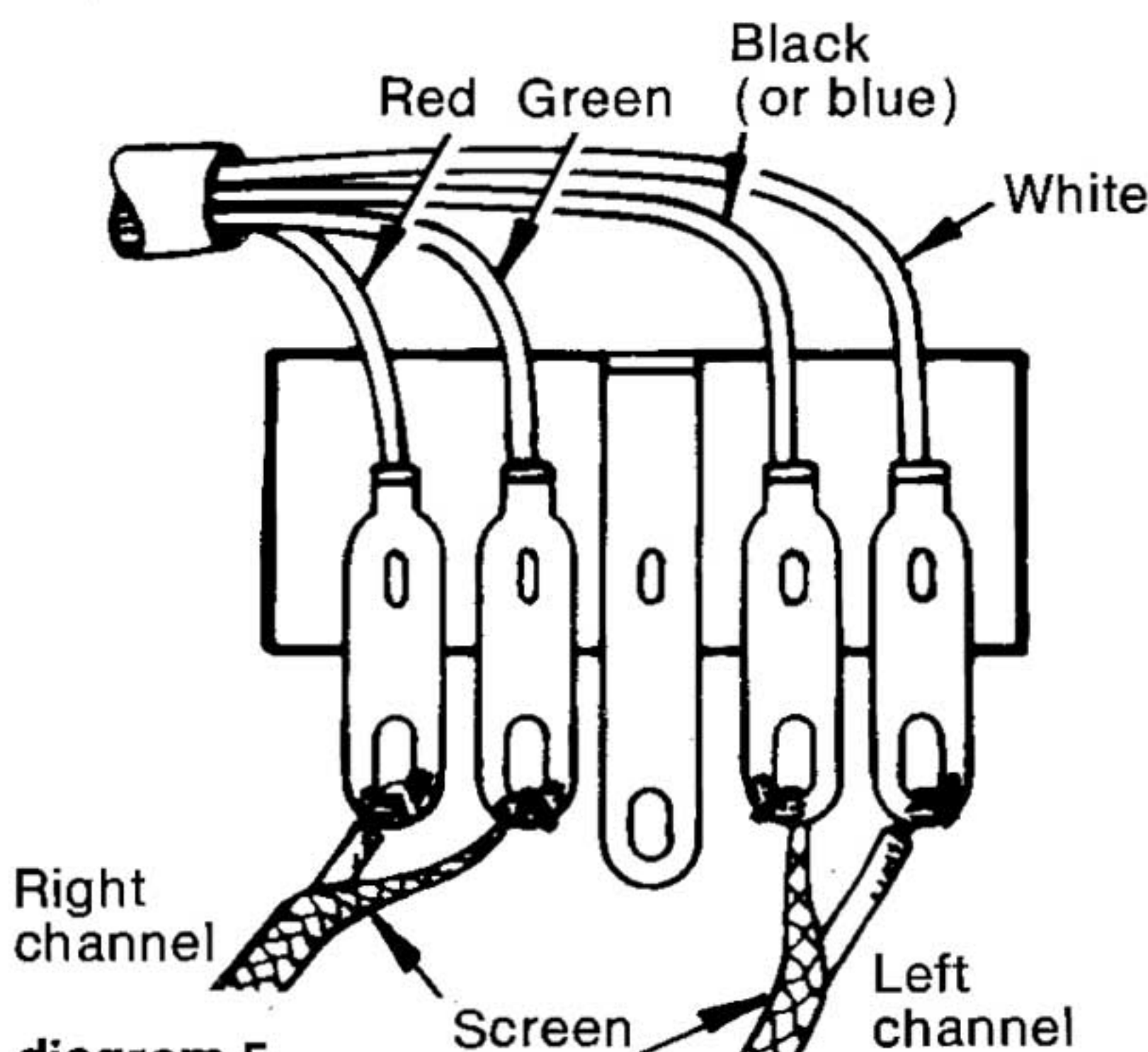

diagram 5

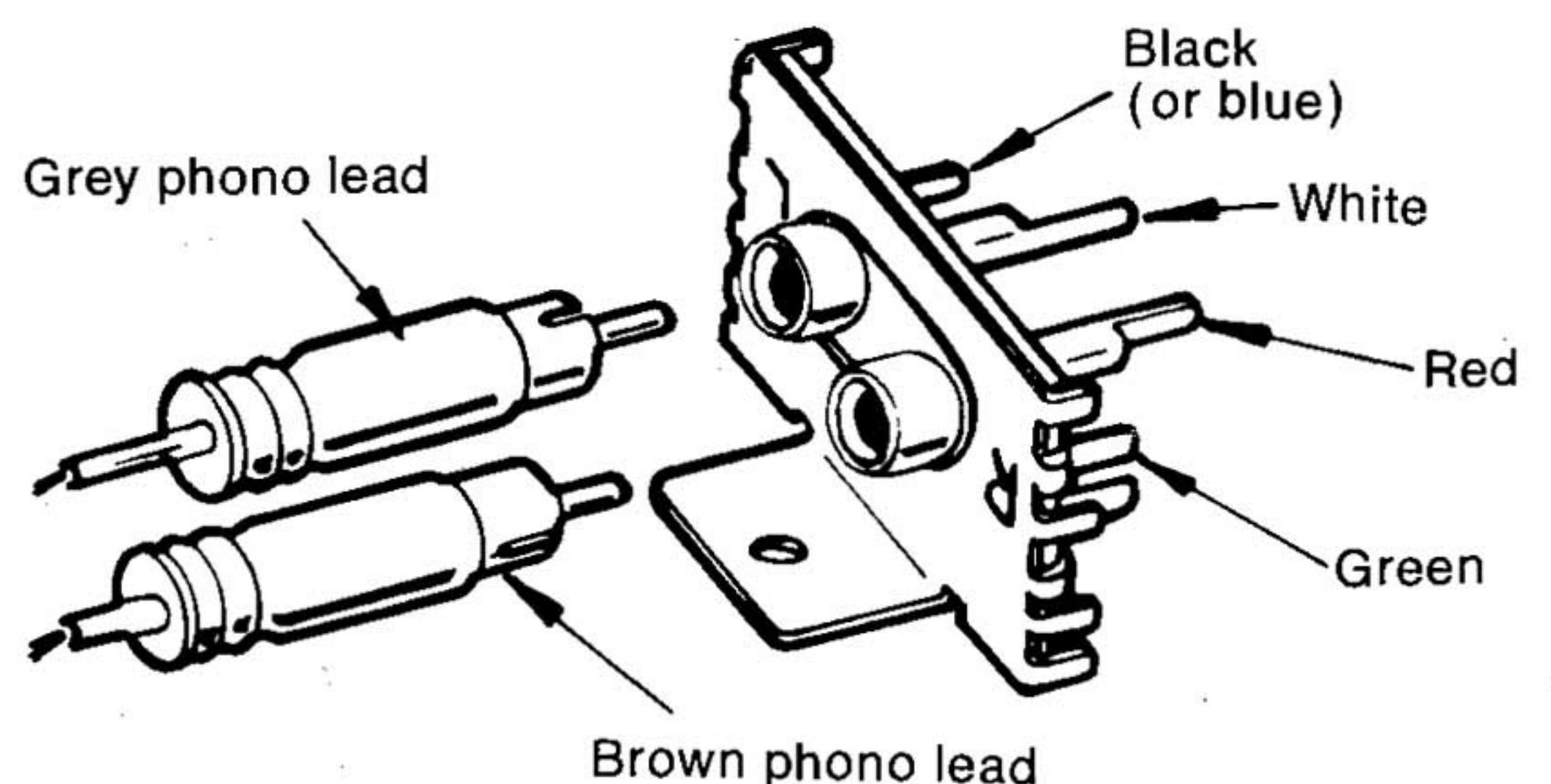

diagram 6

fitting pickup cartridge

Garrard slide-in cartridge carrier, type C2, is used on the SP25 Mk III and is usually supplied less cartridge. The cartridge fixing kit, part number 59048, contains fixing accessories (less cartridge) comprising a pickup head weight, a tilt wedge and pairs of screws of various lengths.

With most cartridges the tilt wedge helps obtain the correct tracking angle for the stylus (extra-deep cartridges may not require the wedge). The wedge should be positioned between the cartridge and the carrier with its thin edge to the front and its identification mark facing the carrier. (Remove wedge or put thick edge to front if back of cartridge fouls record.) Thus fit the cartridge – which must have a 2-hole fixing bracket – to the carrier, with the tilt wedge between them, using the pair of screws of most suitable length. If the pickup cartridge is too light to come within the counterbalance range, include the pickup head weight next to the carrier in this assembly. Diagram 7 shows the order in which the full assembly is made.

Connect the colour coded leads on the carrier to the connection tags for the cartridge, but do not solder leads directly to the cartridge as this may damage cartridge elements. Connect leads as follows:

- Red to right channel
- Green to right channel ground
- White to left channel
- Black (or Blue) to left channel ground

Information on its connection is usually supplied with the cartridge. For cartridges with 3 connections use the green as common or join the green and black (or blue) leads together as the common connection. For mono cartridges use the red and green leads only. Insulate and tuck away any leads not required. Carefully slide the cartridge carrier so that it clips into place in the pickup head. When removing the cartridge carrier, grip its sides and pull it forward from the pickup head.

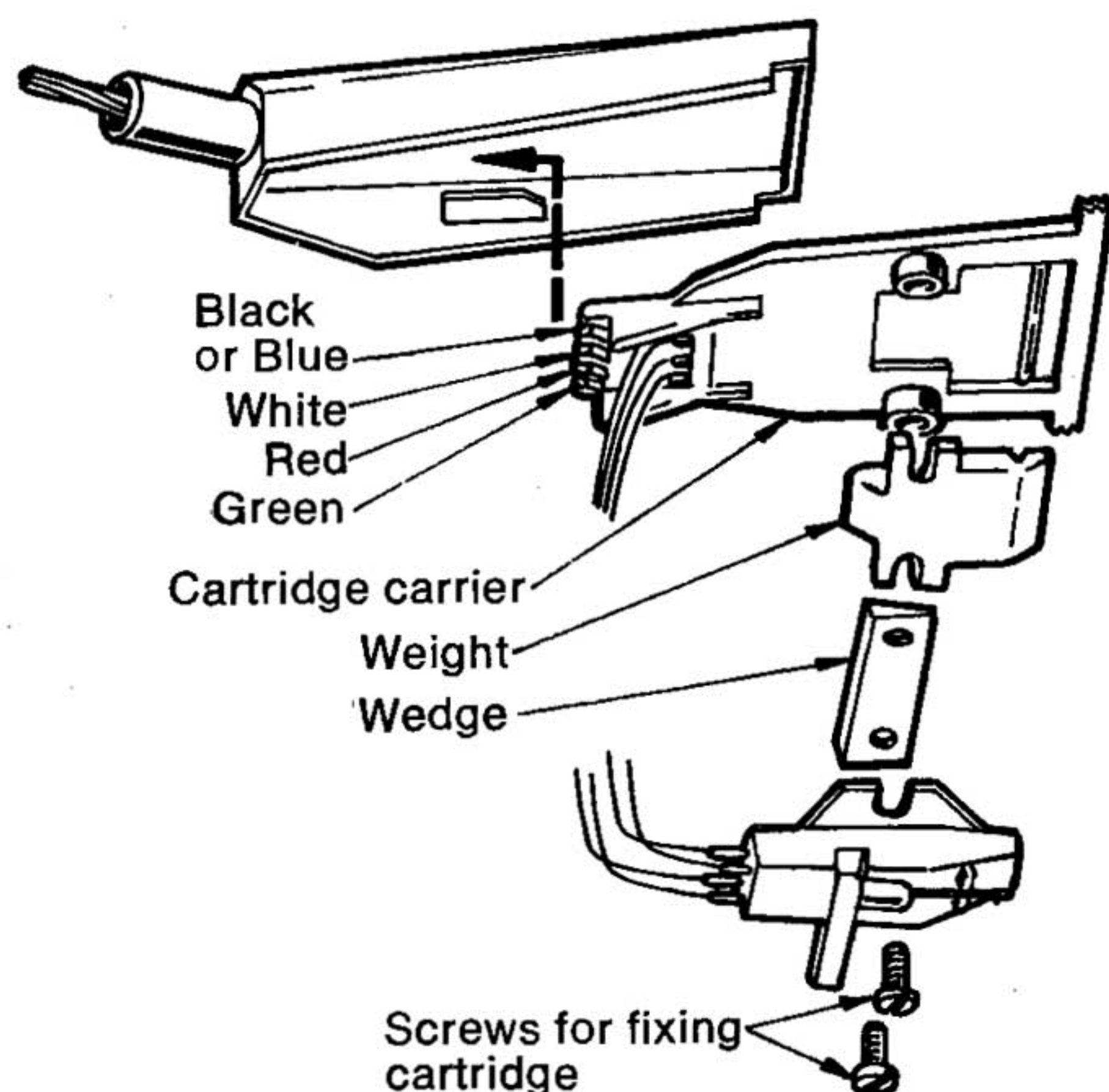

diagram 7

installation adjustments

Pickup stylus force

See diagram 8.

- 1 Set dial to zero.
- 2 Slacken pickup arm counterbalance weight clamp screw.
- 3 Check that mechanism is not engaged by rotating turntable slowly clockwise by hand until free running. Make sure cue and pause control is set down.
- 4 Lift pickup arm from rest.
- 5 Slide counterbalance weight to position which balances pickup arm with the stylus tip about $\frac{1}{8}$ in (3mm) above the turntable mat.
- 6 Clamp counterbalance weight.
- 7 Set dial to stylus force recommended for the cartridge. Numbers on dial represent 0 to 5 grams.

Note that when supplied with pickup cartridge in its module form, the cartridge type usually supplied is a Shure M75-65 which should be set to a stylus force of 2 to 3 grams. A minimum stylus force of 2 grams is recommended for cartridges used with SP25 Mk III.

Pickup arm bias compensator

This unit has a calibrated bias compensator. Move the bias compensator control shown in diagram 8 along its scale to the figure which corresponds to the previously set figure for stylus force. The bias compensator compensates for the small side forces acting on the pickup arm.

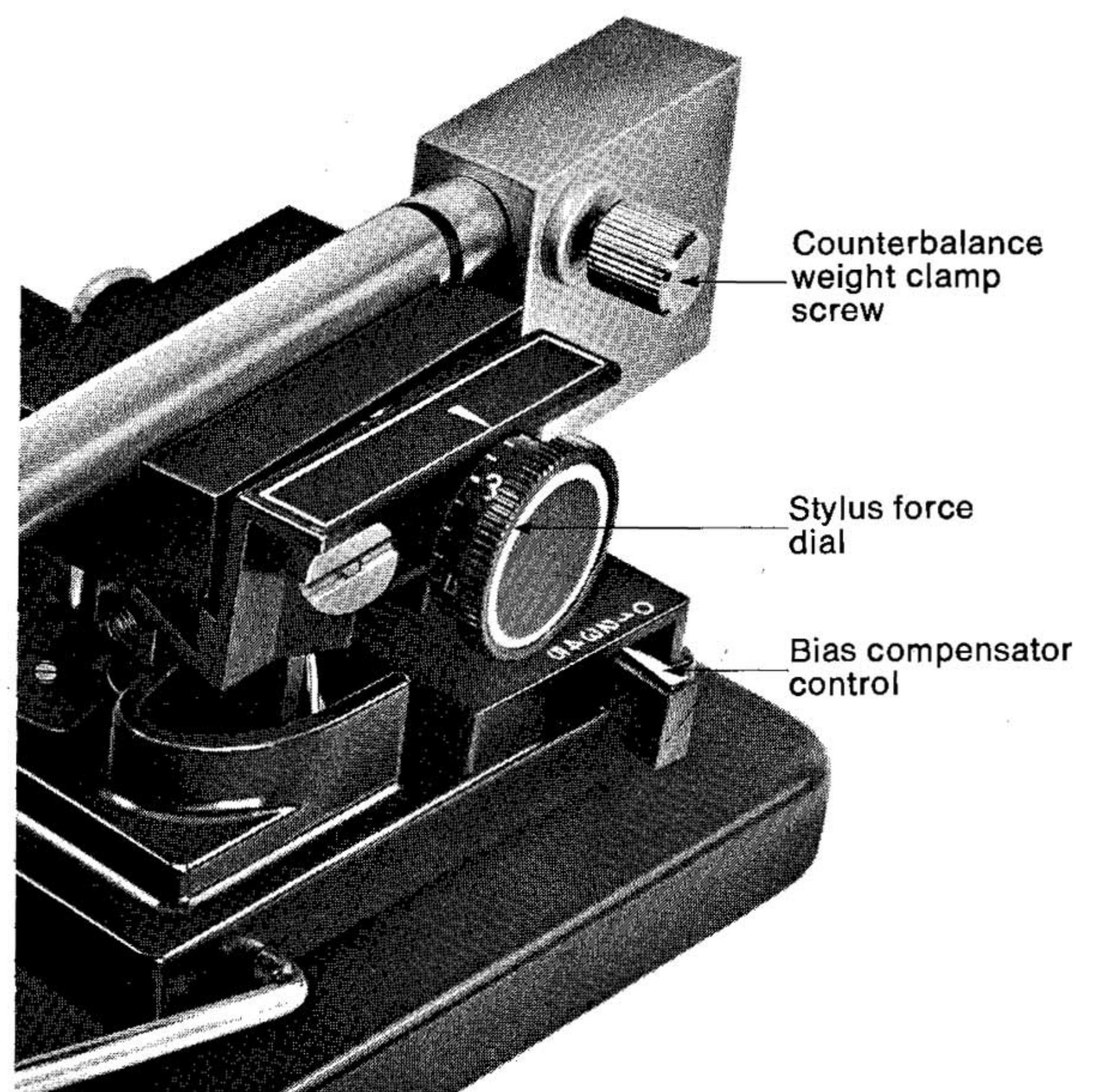

diagram 8

operating instructions

Free the pickup arm by releasing its catch and remove the stylus guard, if fitted. Check that the speed (and record size settings for auto play) also the stylus are correct for the records to be played and that the transit screws are turned fully clockwise.

Automatic play

- 1 Place the chosen record on the turntable.
- 2 Move the operating control to 'Auto', pause and release the control, which will reset later in the cycle.
- 3 The record will be played automatically, the pickup will return to its rest and the unit will switch off.

Reject

Move the operating control to 'Auto' and immediately return it to 'Manual'; the pickup will lift from the record being played, return to its rest and the unit will switch off.

Manual play

- 1 Place the chosen record on the turntable.
- 2 Move the operating control to 'Manual'.
- 3 Place the pickup on the record by hand.

Cue and pause

When playing a record manually, the cue and pause control may be used to place the pickup on the record, also to raise or lower the pickup at any selected point. Record play can be temporarily interrupted in a similar way.

To raise the pickup, lift the cue and pause control, to lower the pickup, steadily lower the cue and pause control.

Large hole records

An adaptor is provided which fits over the record spindle in order to locate and thus play 7in 45 rev/min large hole records.

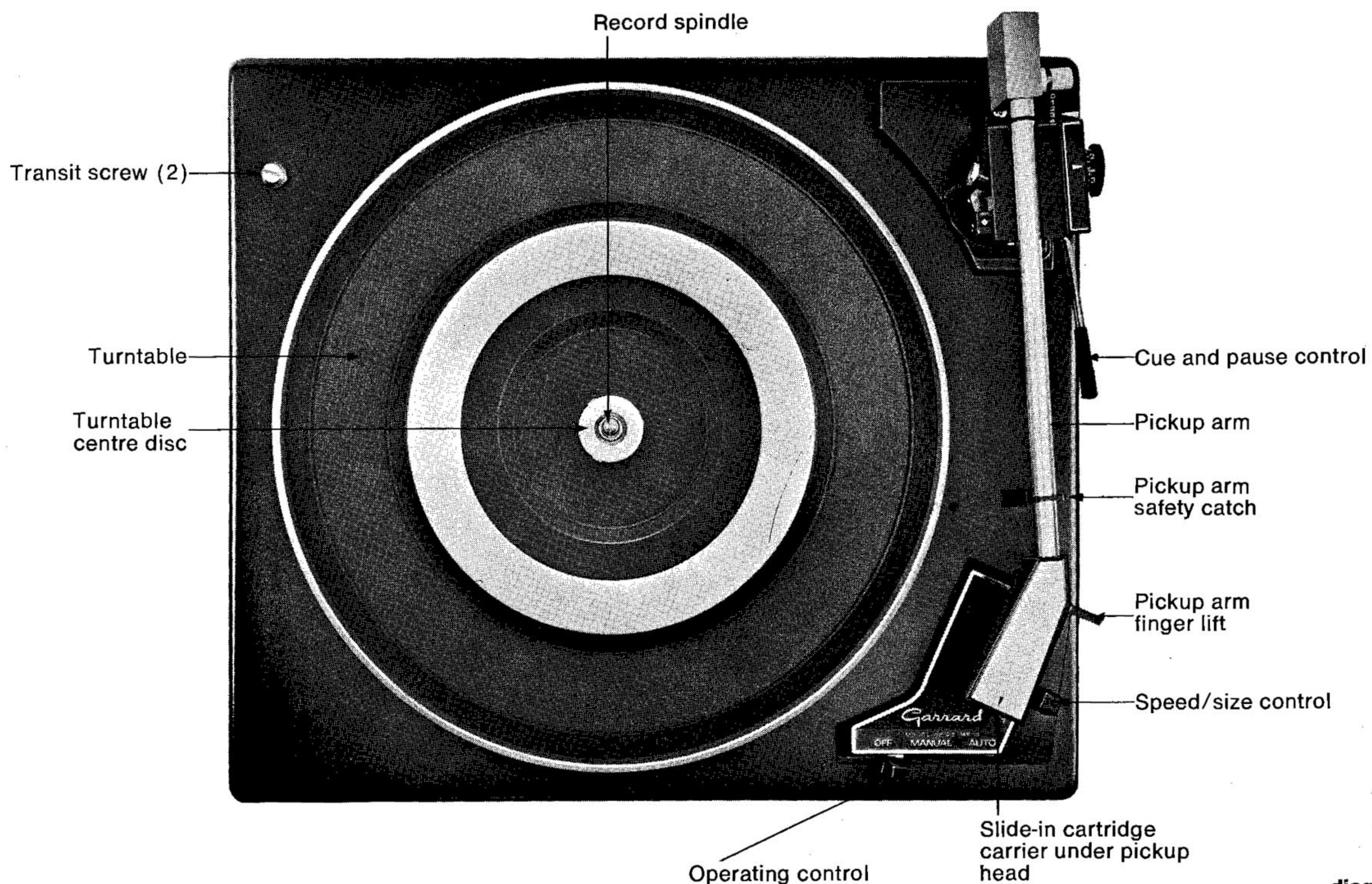

diagram 9

maintenance

Caution

Disconnect power supply and protect stylus before carrying out maintenance.

To remove the turntable

Pull out the record spindle then remove the centre disc from the turntable mat, taking care not to buckle the disc. Now remove the turntable clip (see diagram 10) and lift the turntable with equal pressure on diametrically opposite sides.

To replace the turntable

Check that the bearing and spindle are clean (but lubricated) and that the gap in the teeth of the cam gear is adjacent to the turntable spindle with the trip pawl pushed away from the spindle (see diagram 11). The turntable will now slide on easily. Fit the retaining clip in the groove of the turntable spindle with the record spindle removed as in diagram 10.

Lubrication

The motor, turntable spindle and rubber intermediate wheel bearings are of the oil retaining type and rarely need lubricating. When the need for oil is apparent, hold the intermediate wheel away from the motor pulley and apply a few drops of fine grade machine oil to the top motor bearing. Also oil the intermediate wheel bearing, the turntable bearing and occasionally the bottom motor bearing, including lever pivot points if stiffness in the mechanism becomes noticeable. Remove surplus oil with a clean cloth. Diagrams 11 and 12 show further points where a little oil or grease can be used beneficially. On no account apply oil to the damped cueing system.

Damped cueing system

The cueing system for this unit is assisted by the damping action of Garrard Damping Fluid. This is applied to the top

section of the lifting spindle and the bore of the lifting platform. If the damping becomes ineffective, remove the pickup arm and bracket (see 'Dismantling' section) and turn the top of the pickup lever aside sufficiently to remove the plastic lifting platform. Although the top of the lifting spindle can be cleaned and recoated in this position (especially by pushing it up against its spring beneath the unit) better results are obtained by removing the pickup cam (see 'Dismantling' section) and withdrawing the lifting spindle unit from below.

Note that a lifting platform with lifting spindle assembled is available as a spares item in which the important viscous bond between the spindle and the platform is factory-sealed. If fitting this spares item, assemble it from the top of the unit, not allowing its components to come apart, then fit lifting washer and spring.

Clean off surplus damping fluid from around the cueing system with a clean rag and if refitting the lifting platform make sure that the top tail of its torsion spring (if fitted) is wound so that it pushes against the back of the boss on the upper casting. On later models the damped cueing system is supplemented by spring (part no. 44554) between a lug on lifting platform (166) and a lug on upper casting (26).

To remove motor pulley

The pulley has minimum clearance between its bore and the motor shaft to ensure true running. If, with its locking screws loosened, the pulley is tight on the shaft, apply gentle heat to the base of the pulley for about 30 seconds using a small clean soldering iron; the pulley should then slide off easily. Use this method to fit a new pulley if necessary, but take care not to damage the intermediate wheel or motor wiring when using a soldering iron.

To remove unit from module base

See 'Dismantling' section and diagram 19.

To fit turntable clip

2. Press clip down here to spring over chamfer on turntable spindle

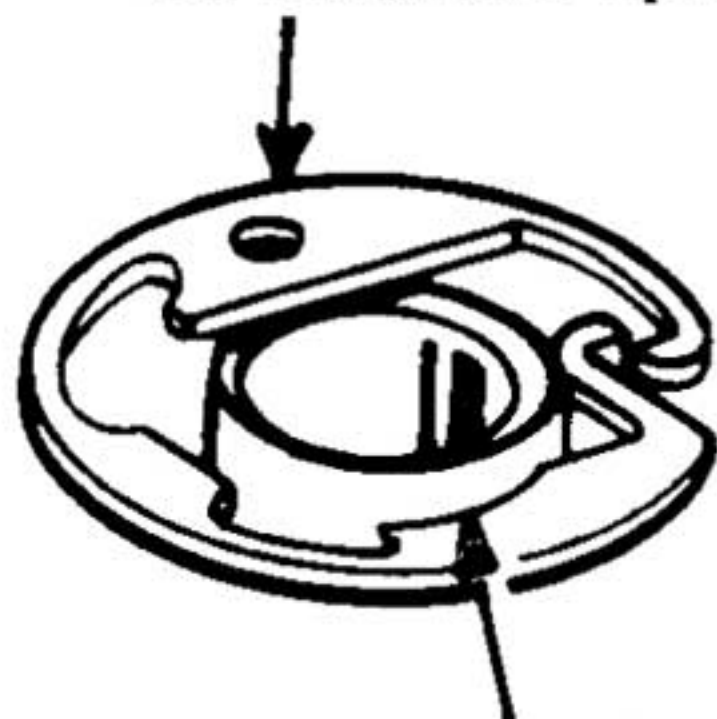

1. Engage clip in turntable spindle slot with hole in clip at rear

To remove, lever this face back to position shown opposite

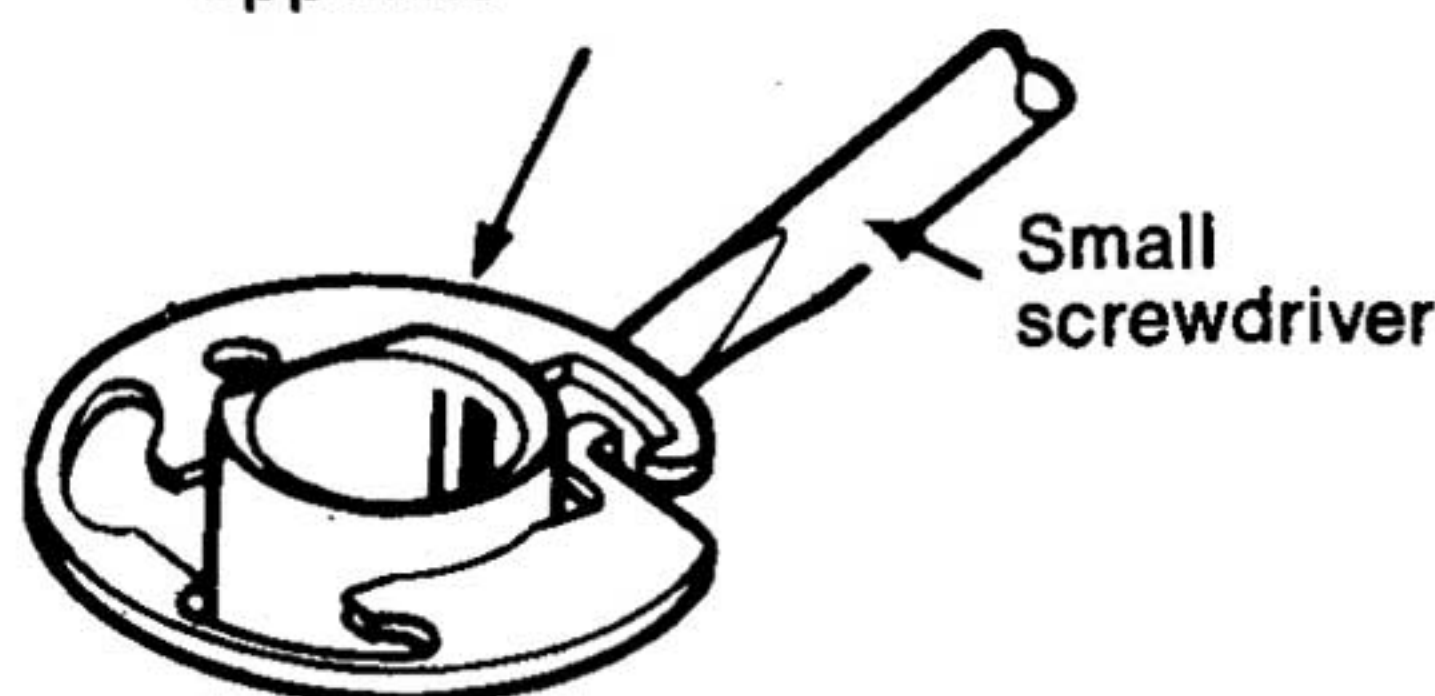

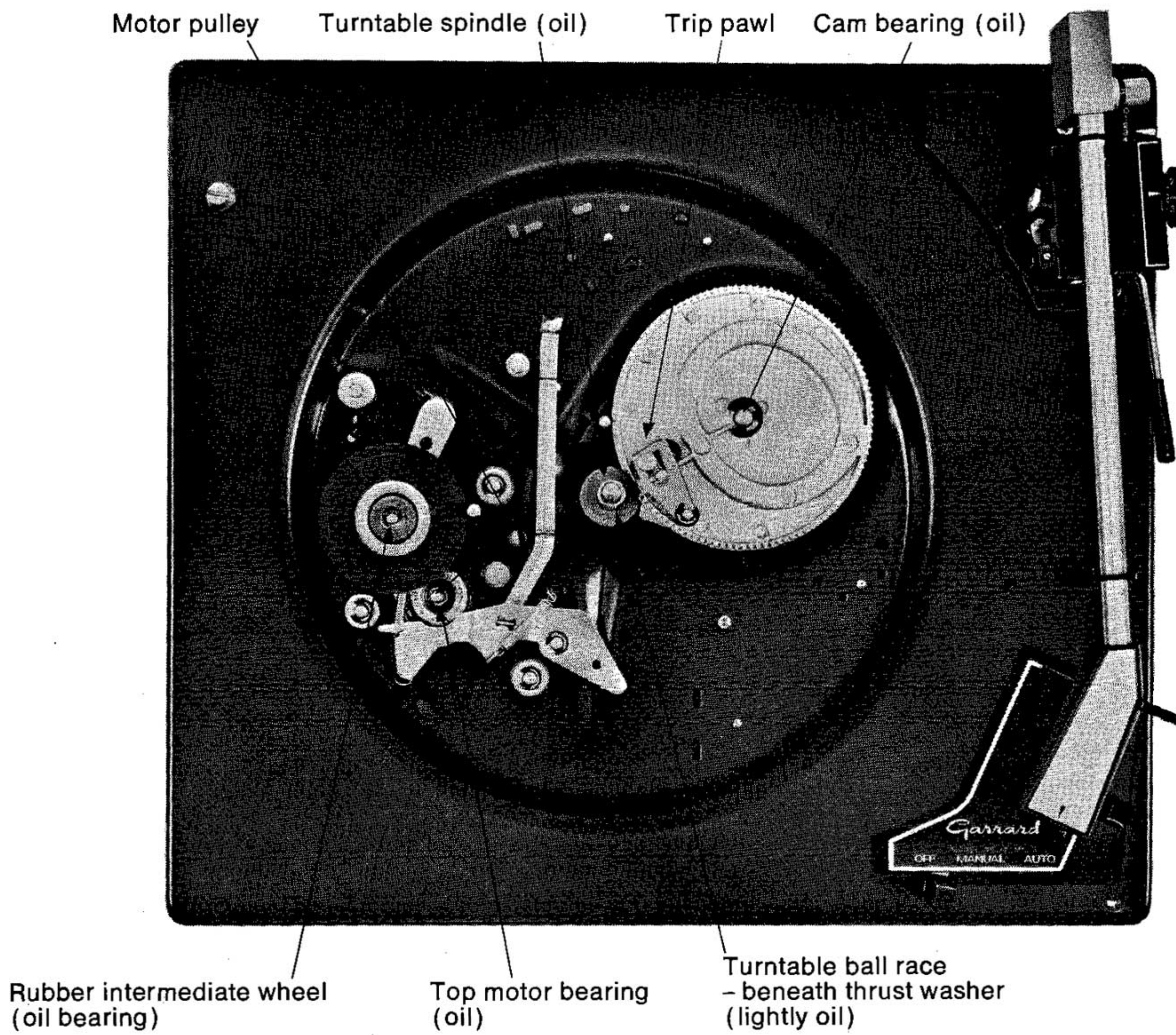

diagram 11

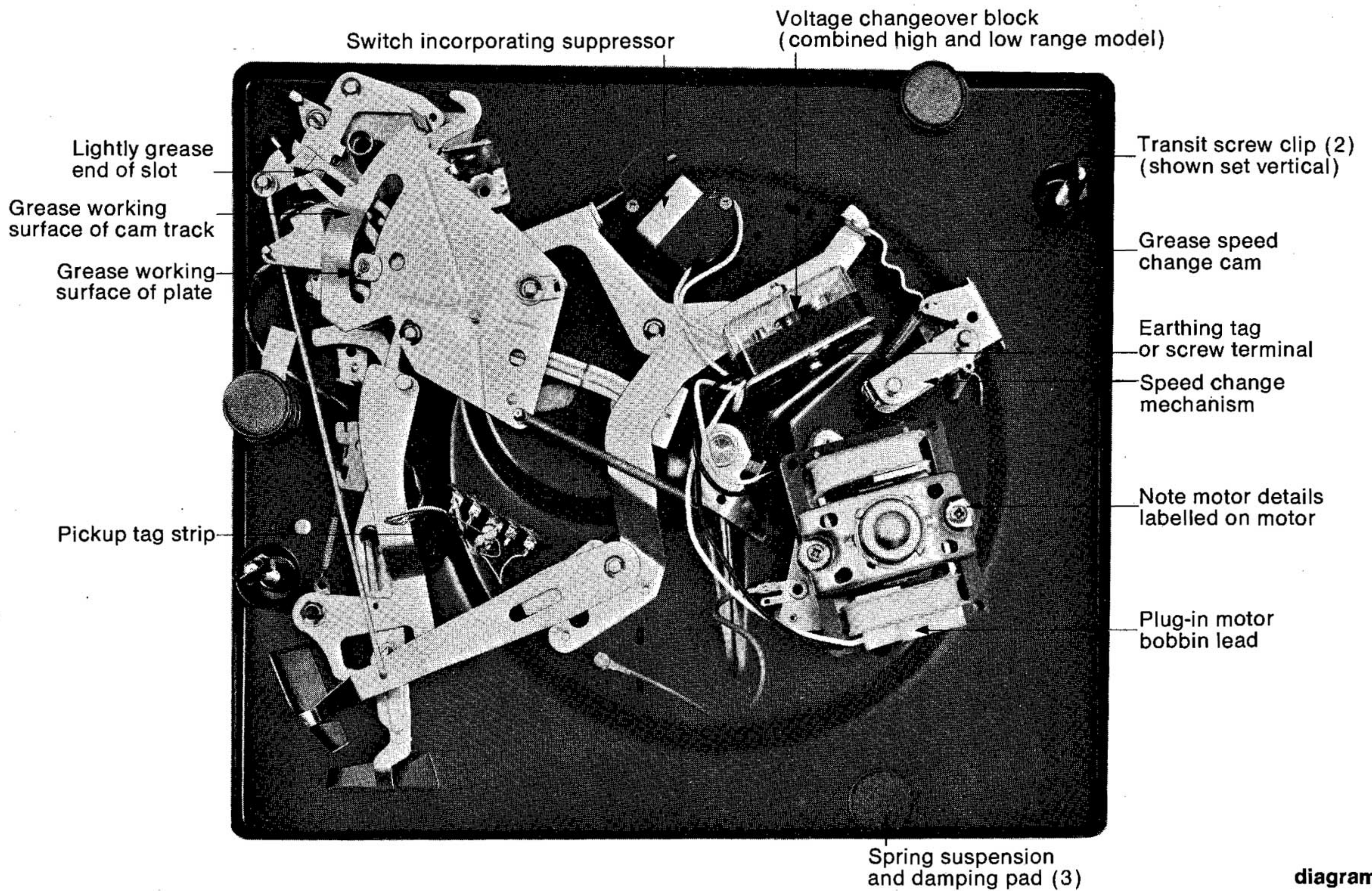

diagram 12

parts list for model SP25 Mk III

When ordering spares, quote the model type, code (from inspection label), part number, colour if part is enamelled or plastic, and voltage range for motor parts.

The code for Model SP25 Mk III is 74750 plus its following three-figure stroke number, from the inspection label.

For other models in the 'Autoslim' series, refer to their particular exploded view. Note for all models, description and code number with three-figure stroke number, is most important in ordering.

| Ref. No. | Garrard Part No. | Description | Ref. No. | Garrard Part No. | Description | Ref. No. | Garrard Part No. | Description |
|----------|------------------|--|----------|------------------|--|----------|------------------|---|
| 1 | 74274 | Bush | 59 | 00451/002 | Nut (quote 991/4/00451/002) | 115 | 72993 | Selector link |
| 2 | 75070 | Counterbalance weight (with clamp screw) | 60 | 41218/011 | Washer | 116 | 72507 | Operating control knob |
| 3 | 58919 | Clamp screw | 61 | 41218/011 | Washer | 117 | 71590 | Operating control lever with knob |
| 4 | 74232 | Pickup arm tube extension | 62 | 00451/002 | Nut (quote 991/4/00451/002) | 118 | 72507 | Speed/size control knob |
| 5 | 74274 | Bush | 63 | 00201/002 | Spring washer (quote 991/4/00201/002) | 119 | 00451/002 | Nut (quote 991/4/00451/002) |
| 6 | 75059 | Pickup arm assembly (with body) | 64 | 60867 | Stud | 120 | 60391 | Earth lead assembly |
| 7 | 74462 | Pickup body assembly | 65 | 60362 | Bracket | 121 | 43129/001 | Rubber motor grommet |
| 8 | 44893 | Stylus force spring | 66 | 54926 | Voltage changeover link | 122 | 00852/012 | Shakeproof washer (quote 999/4/00852/012) |
| 9 | 01512/001 | Self-tap screw (quote 999/4/01512/001) | 67 | 54926 | Voltage changeover link | 123 | 41759 | Spring |
| 10 | 42512 | Shakeproof washer | 68 | 58179 | Cover for voltage changeover block | 124 | 44328 | Screw |
| 11 | 01512/001 | Self-tap screw (quote 999/4/01512/001) | 69 | 00432/007 | Spring clip (quote 999/4/00432/007) | 125 | 73662 | Roller |
| 12 | 59003 | Pivot screw | 70 | 01166/002 | Spring clip (quote 999/4/01166/002) | 126 | 01515/016 | Earth screw (quote 999/4/01515/016) |
| 13 | 74505 | Stylus force marker plate | 71 | 74744 | Speed/size control (with knob) | 127 | 01515/016 | Pickup lead connector screw (quote 999/4/01515/016) |
| 14 | 72183 | Stylus force adjustment lever | 72 | 44708 | Lifting spring | 128 | 73057 | Pickup lead connector tag strip |
| 15 | 74504 | Pickup bracket assembly (with cross pivots and dial) | 73 | 58208 | Support bracket with blade | 129 | 44943 | Loop spring |
| 16 | 41868 | Spring clip | 74 | 58274 | Speed lever | 130 | 00432/007 | Spring clip (quote 999/4/00432/007) |
| 17 | 72185 | Stylus force adjustment dial | 75 | 58211 | Index bracket with roller | 131 | 00432/007 | Spring clip (quote 999/4/00432/007) |
| 18 | 72186 | End plate | 76 | 41848 | Index spring | 132 | 00432/007 | Spring clip (quote 999/4/00432/007) |
| 19 | 43860 | Spring clip | 77 | 75363 | Speed cam | 133 | 01515/020 | Pickup rest screw (quote 999/4/01515/020) |
| 20 | 40826 | Washer | 78 | 75379 | Damping weight | 134 | 58749 | Cushion ring |
| 21 | 72184 | Pivot pin | 79 | 75083 | Unit plate unit | 135 | 41225 | Thrust washer |
| 22 | 59756 | Pivot screw | 80 | 41218/026 | Washer for motor grommet | 136 | 58229/002 | Ball race |
| 23 | 30952/001 | Cover screw (quote 999/4/30952/001) | 81 | 00432/007 | Spring clip (quote 999/4/00432/007) | 137 | 41225 | Thrust washer |
| 24 | 74786 | Bias compensator assembly | 82 | 41218/026 | Washer for motor grommet (2 labelled) | 138 | 73139 | Cushion ring |
| 25 | 44293 | Height adjusting screw | 83 | 00432/007 | Spring clip (quote 999/4/00432/007) | 139 | 59048/072 | Pickup hardware kit |
| 26 | 74736 | Upper casting assembly | 84 | 00432/007 | Spring clip (quote 999/4/00432/007) | 140 | 73439 | Insulation piece |
| 27 | 72997 | Bearing pad | 85 | 00201/001 | Spring washer (quote 991/4/00201/001) | 141 | 44279 | Anchor screw |
| 28 | 72997 | Bearing pad | 86 | 43855 | Transit clip | 142 | 72537 | Anchor pad |
| 29 | 73031 | Cueing lever unit (separate knob 74267) | 87 | 71824 | Tension link | 143 | 44475 | Spring |
| 30 | 73542 | Spring mounting with pad (3 off per unit) | 88 | 44819 | Intermediate wheel spring | 144 | 03053/005 | Locknut (quote 999/4/03053/005) |
| 31 | 70447 | Foam damping pad (3 off per unit) | 89 | 71357 | Tension lever | 145 | 72181 | Spindle |
| 32 | 76337 | Lower casting assembly | 90 | 00432/007 | Spring clip (quote 999/4/00432/007) | 146 | 44340 | Height adjustment screw |
| 33 | 43200 | Ball bearing | 91 | 41506 | Tension spring | 147 | 40268 | Lowering position adjustment screw |
| 34 | 44462 | Friction spring | 92 | 71545 | Support lever unit | 148 | 00687/002 | Spring clip (quote 999/4/00687/002) |
| 35 | 01574/057 | Screw (quote 999/4/01574/057) | 93 | 41219/005 | Fibre washer | 149 | 00451/003 | Nut (quote 991/4/00451/003) |
| 36 | 41218/013 | Washer | 94 | 58220 | Intermediate wheel | 150 | 00431/024 | Spring clip (quote 999/4/00431/024) |
| 37 | 01574/057 | Screw (quote 999/4/01574/057) | 95 | 41219/010 | Plastic washer | 151 | 58328 | Main cam |
| 38 | 00432/007 | Spring clip (quote 999/4/00432/007) | 96 | 00431/010 | Spring clip (quote 999/4/00431/010) | 152 | 43855 | Transit clip |
| 39 | 42561 | Spring washer | 97 | 74224 | Pickup head decor plate | 153 | 01577/006 | Switch screw (quote 999/4/01577/006) |
| 40 | 58316 | Collar | 98 | 75032 | Turntable packing ring | 154 | 58327 | Reject lever |
| 41 | 72982 | Selector lever | 99 | 74738 | Turntable assembly (non-magnetic top) | 155 | 73671 | Return spring assembly |
| 42 | 00431/015 | Spring clip (quote 999/4/00431/015) | 99 | 74739 | Turntable and mat assembly (non-magnetic top) | 156 | 73563 | Anchor plate |
| 43 | 44935 | Overload spring | 99 | 74169/003 | Steel turntable and mat assembly | 157 | 73558 | Inter control lever unit |
| 44 | 74783 | Pickup lever | 100 | 74166 | Turntable mat (for 74738) | 158 | 44825 | Spring |
| 45 | 58348 | Friction link | 101 | 73033 | Turntable centre disc (for 74739) | 159 | 74491 | Spring retainer |
| 46 | 41218/009 | Lifting spindle washer | 101 | 75333 | Steel turntable centre disc | 160 | 01574/057 | Screw (quote 999/4/01574/057) |
| 47 | 44958 | Lifting spindle spring | 102 | 73030 | Zone ring (state outside diameter) | 161 | 01575/009 | Screw (quote 999/4/01575/009) |
| 48 | 73128 | Selector actuating lever | 103 | 72698 | Large hole record adaptor | 162 | 74214 | Pickup rest with clip |
| 49 | 73272 | Pickup cam | 104 | 75013 | Manual spindle | 163 | 44120 | Transit screw (2 off per unit) |
| 50 | 00432/007 | Spring clip (quote 999/4/00432/007) | 105 | 75066 | Contact moulding with pickup lead assembly | 164 | 75058 | Spacer |
| 51 | 44715 | Spring | 106 | 73361 | Pickup cartridge carrier, type C2 | 165 | 00687/002 | Spring clip (quote 999/4/00687/002) |
| 52 | 60660 | Motor (quote power supply details) | 107 | 75392 | Tilt wedge | 166 | 76807 | Lifting platform assembly (with spring 47) |
| 53 | 43129/001 | Rubber motor grommet | 108 | 74732 | Control moulding | 167 | 74245 | Plunger |
| 54 | 00245/058 | Screw (quote 991/4/00245/058) | 109 | 70928 | Bearing pad | 168 | 44463 | Spring |
| 55 | 41218/008 | Washer | 110 | 60365 | Motor wiring loom with switch and changeover block | 169 | 74248 | Friction cap |
| 56 | 43129/001 | Rubber motor grommet | 111 | 58310 | Switch lever | 170 | 40906 | Locking washer |
| 57 | 60846 | 50Hz pulley (with screws) | 112 | 72681 | Auto stop link | 171 | 70585 | Pivot screw |
| 57 | 60845 | 60Hz pulley (with screws) | 113 | 00432/007 | Spring clip (quote 999/4/00432/007) | 172 | 72899 | Overload nut |
| 58 | 51333 | Insulation plate | 114 | 01577/006 | Switch screw (quote 999/4/01577/006) | 173 | 77403 | Turntable clip (beneath centre disc) |

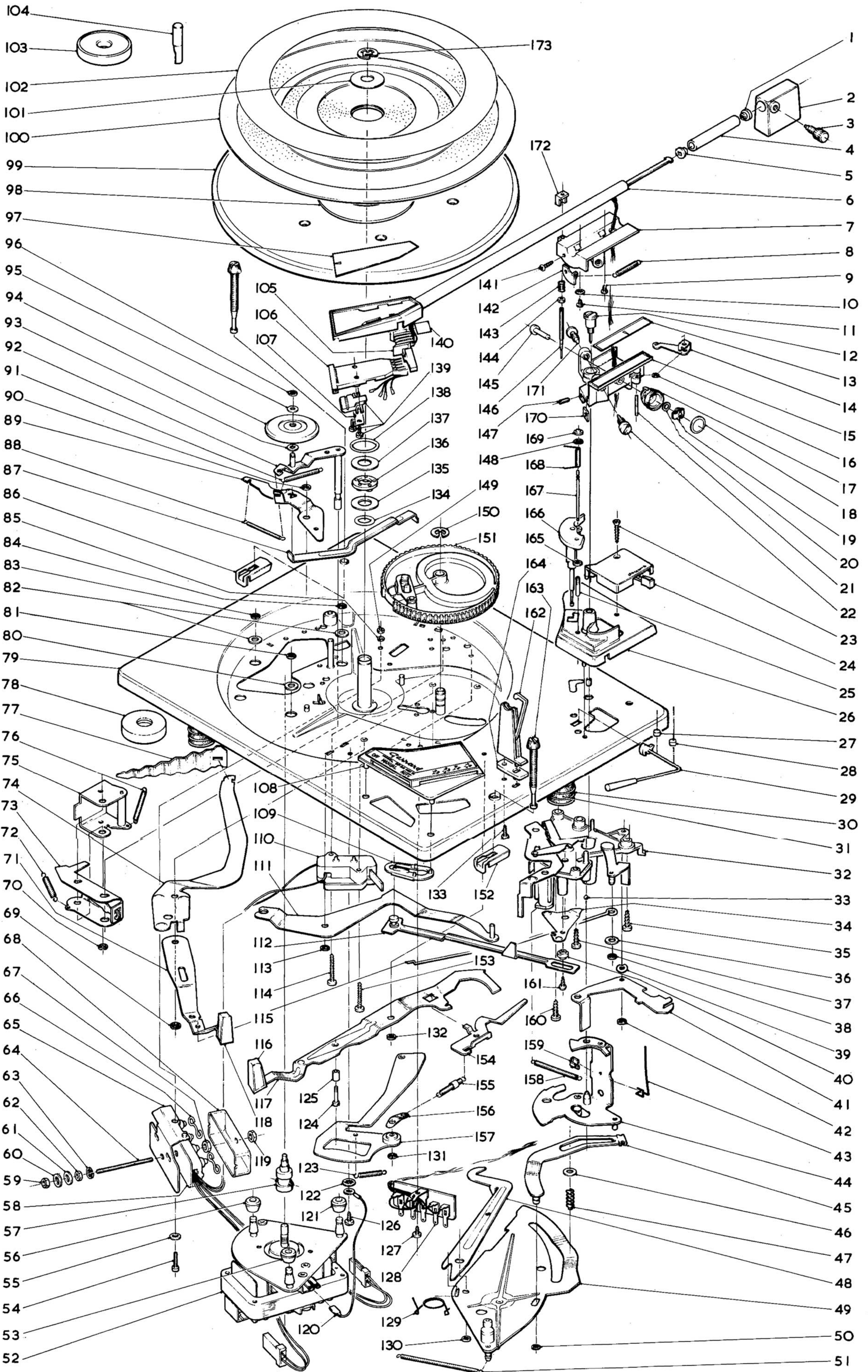

UNFOLD FOR EXPLODED VIEW

Note: This centre page may be removed from the service manual stapling if desired.

Module SP25 Mk III parts not illustrated on exploded view. (Order as described, quoting code number 76480 plus following three-figure stroke number from inspection label.)

| Part No. | Description |
|-----------|--------------------------------------|
| 76432/001 | Cover, complete |
| 76404 | Stay assembly |
| 76431/001 | Mounting base, teak style |
| 76431/002 | Mounting base, walnut style |
| 76431/003 | Mounting base, rosewood style |
| 76431/004 | Mounting base, white style |
| 77260 | Clip-in lead clamp for mains lead |
| 76329 | Clip-in lead clamp for phono leads |
| 61096 | Clamp bar (quote 501/7/61096) |
| 01428/005 | Clamp screws (quote 999/4/01428/005) |
| 77259 | 3-core mains lead |
| 76416/004 | 2-core mains lead |
| 78588/001 | Phono lead with five pin DIN plug |
| 78582/001 | Twin phono lead, R.C.A. type plugs |

See page 17 for details of other Garrard module bases and covers suitable for these units.

service adjustments

Disconnect the power supply before making adjustments. If necessary move the operating control to 'Auto' and rotate the turntable clockwise by hand to operate.

Pickup lowering position

This adjustment is factory set but can be altered if necessary by turning the horizontal screw shown in diagram 13 clockwise to move the lowering position inwards or counterclockwise to move it outwards.

Pickup height

The height that the pickup lifts off a record can be adjusted by turning the vertical screw shown in diagram 13, clockwise to raise, counterclockwise to lower. Make sure that the tension nut beneath this screw does not turn with the adjusting screw. The pickup height should be set normally so that the arm just clears the top of the pickup rest as it returns automatically.

Cueing height

The pickup height screw just referred to, can be used to give special adjustments to the height to which the pickup lifts when cued. A separate adjusting screw in the lifting platform is factory set and should need no adjustment.

Pickup tracking

If the pickup tracks incorrectly, check that the correct stylus is in use and is clean and not worn. (If a mono cartridge is fitted it is recommended that it be of a type suitable for playing stereo records as mono.) See that the pickup leads allow the arm free movement. Make sure that stylus force is as recommended by the cartridge manufacturer and that the bias compensator is set to correspond to the stylus force in use.

Speed

Fast or slow running is very unlikely, but if speed is incorrect, check the motor pulley type against the power supply frequency. The pulley base diameter (shown in diagram 14) is smaller than the 78 rev/min pulley step for 50Hz and larger for 60Hz pulleys. Change the pulley if necessary – see under 'Maintenance' for pulley access and removal information.

If speed varies, check pulley, rubber intermediate wheel and the inside of the turntable rim for traces of oil. Wipe them thoroughly with a clean cloth. Check that the pulley lock screws are equally tight and that the intermediate wheel runs in the centre of the correct pulley step without rubbing the adjacent step. Adjust the intermediate wheel height if necessary by means of the blade shown in diagram 14.

Motor

If the motor fails to start, first check the power supply to the motor. Then with power supply switched off and plug removed, check the motor switch (fitted with suppressor network) and plug-in lead connections (see diagram 15). Check that the switch blades connect when closed and that contacts are clean. Also check that if a voltage changeover block is fitted, the changeover links in the block are tight and set correctly. Make sure that the motor voltage details labelled on the motor correspond to the power supply voltage.

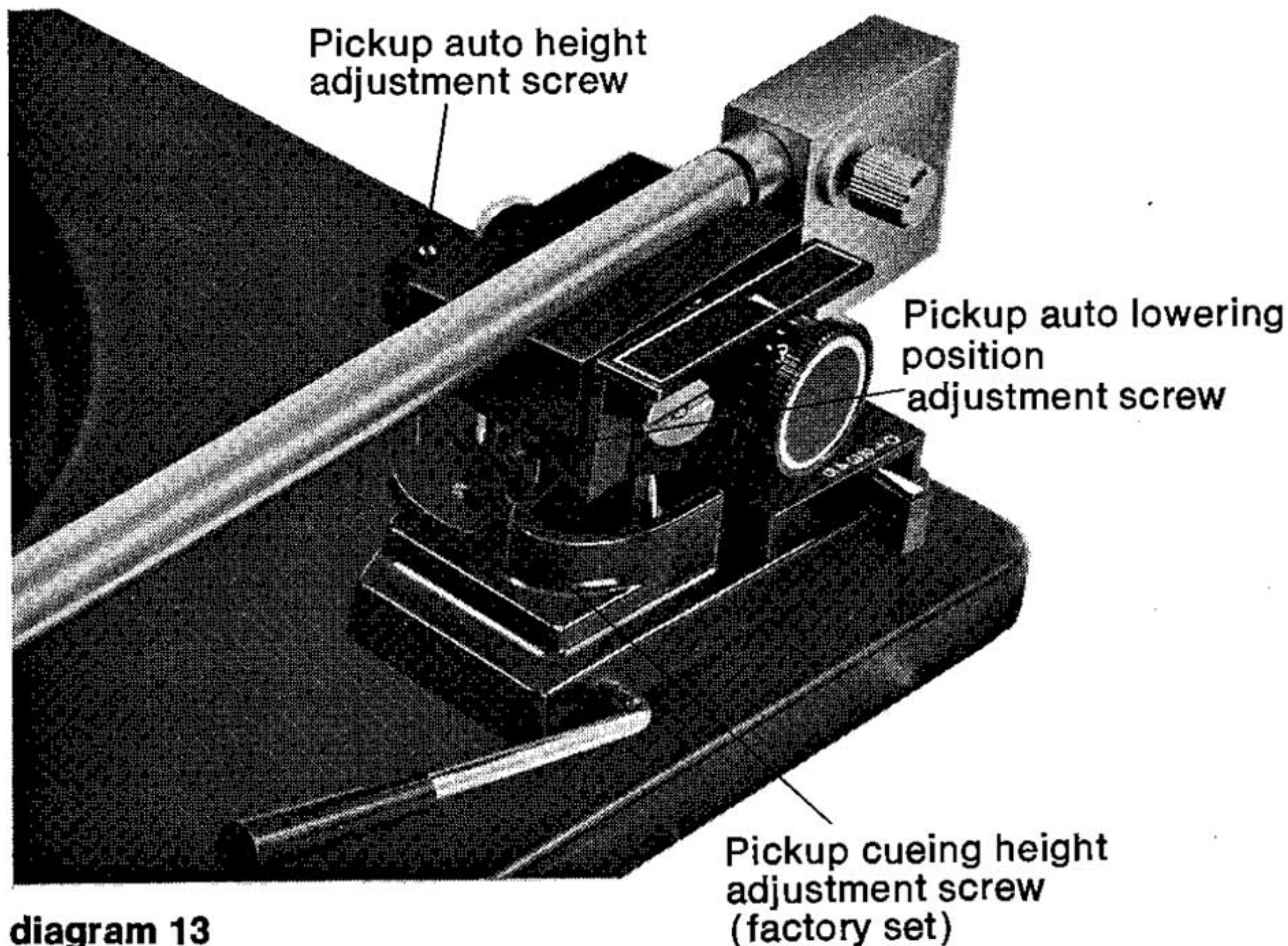

diagram 13

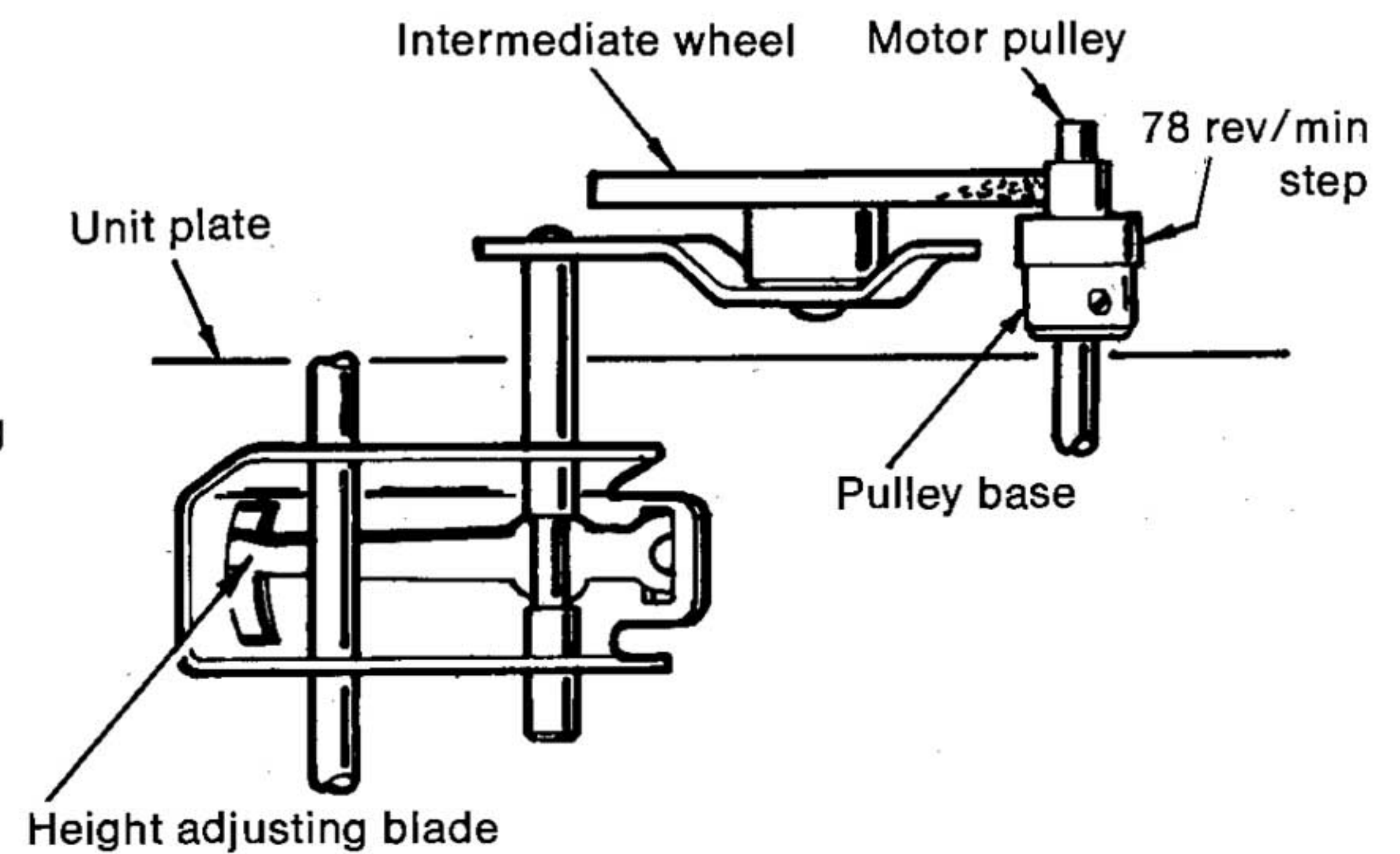

diagram 14

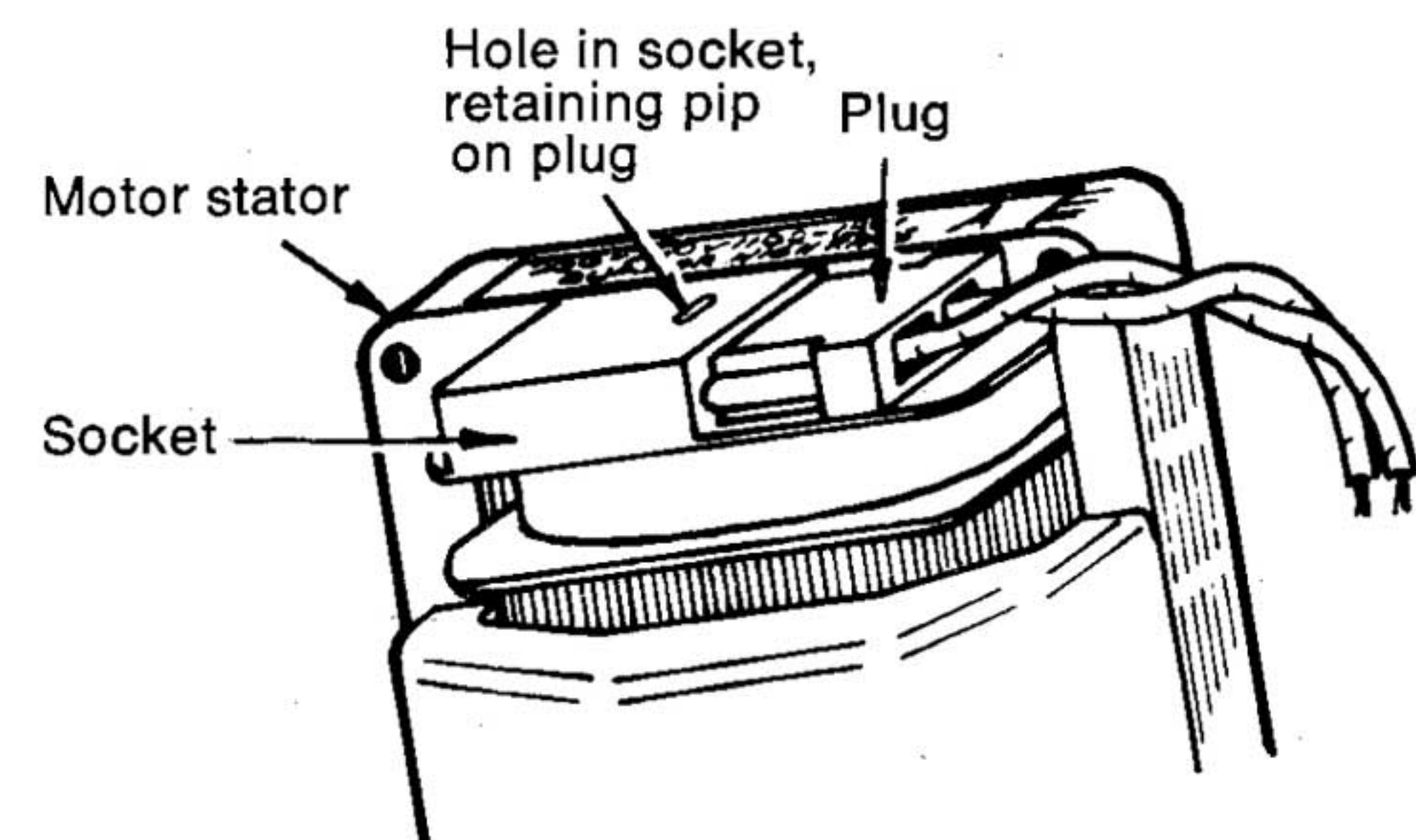

diagram 15

dismantling

Disconnect the unit from the power supply when dismantling parts. Reverse the sequence given to assemble parts, except where stated. Numbers in brackets refer to the exploded view.

Pickup arm

- 1 Note the path of the pickup leads from their tag strip termination to the pickup arm, then carefully disconnect the leads from the tag strip and carefully remove the tape holding the leads to the unit plate.
- 2 Unscrew pivots (171) and (22) and disconnect spring (8) to remove pickup arm (6).
- 3 If required, unscrew pivot screw (12) and remove pickup bracket (15).

When refitting the pickup arm make sure that the pickup leads are not strained, that the spring loaded pivot screw (22) is the outer pivot and that the overload spring (43) is located as in diagram 16.

Pickup cam

- 1 Operate the controls and turn the turntable clockwise by hand to cycle the unit so that the pickup cam (49) has guide plate (shown in diagram 17) in the centre of the long slot.
- 2 Disconnect spring (51) and remove spring clips (50 and 130).
- 3 Ease the pickup cam (49) up from its pivot pin then slide it free of its guide plate at the same time moving the pickup cam so that its roller is not held in the track of main cam (151) by the unit plate slot.
- 4 If required, when the pickup cam (49) is removed, the lifting spindle unit (part of 166) can be withdrawn. (Move the pickup arm inwards so that the pickup lever (44) pivots to give washer (46) clearance.)

When refitting the pickup cam (49) first attach friction link (45) to the cam with spring clip (50) then with selector actuating lever (48) held in position as shown in diagram 18, locate the pickup cam roller in the unit plate slot and main cam track, before locating it under its guide plate and on its pivot pin.

Motor

If there is need to change the motor, Garrard units are fitted with a plug-in wiring loom which facilitates disconnecting the motor.

- 1 The two plugs connecting the loom are held in their respective sockets on the motor bobbin flange by a retaining pip. Carefully slide the tip of a thin screwdriver between the mated faces of plug and socket to separate them by about $\frac{1}{8}$ in, and at this time the plug can be withdrawn by gently pulling it from the socket. See diagram 15. Repeat for second plug.
- 2 Disconnect the earth lead from the motor to the unit plate.
- 3 Remove the turntable (see 'Maintenance' section).
- 4 Remove the spring clips and washers from the top of the three rubber motor mounts.
- 5 Withdraw the motor and its mounting plate.

When refitting a motor, each rubber mount should be in its original position. Make sure the earth lead is securely refitted.

To remove unit from module base of type illustrated

Use a screwdriver to loosen the mains lead strain relief bar (if fitted) and lever back the catches holding both lead clamps at the rear of the base. See diagram 19. Press the unit down on its springs, insert a finger through each hole in the base beneath the transit screws and turn both transit clips vertical so that the unit may be lifted from the base.

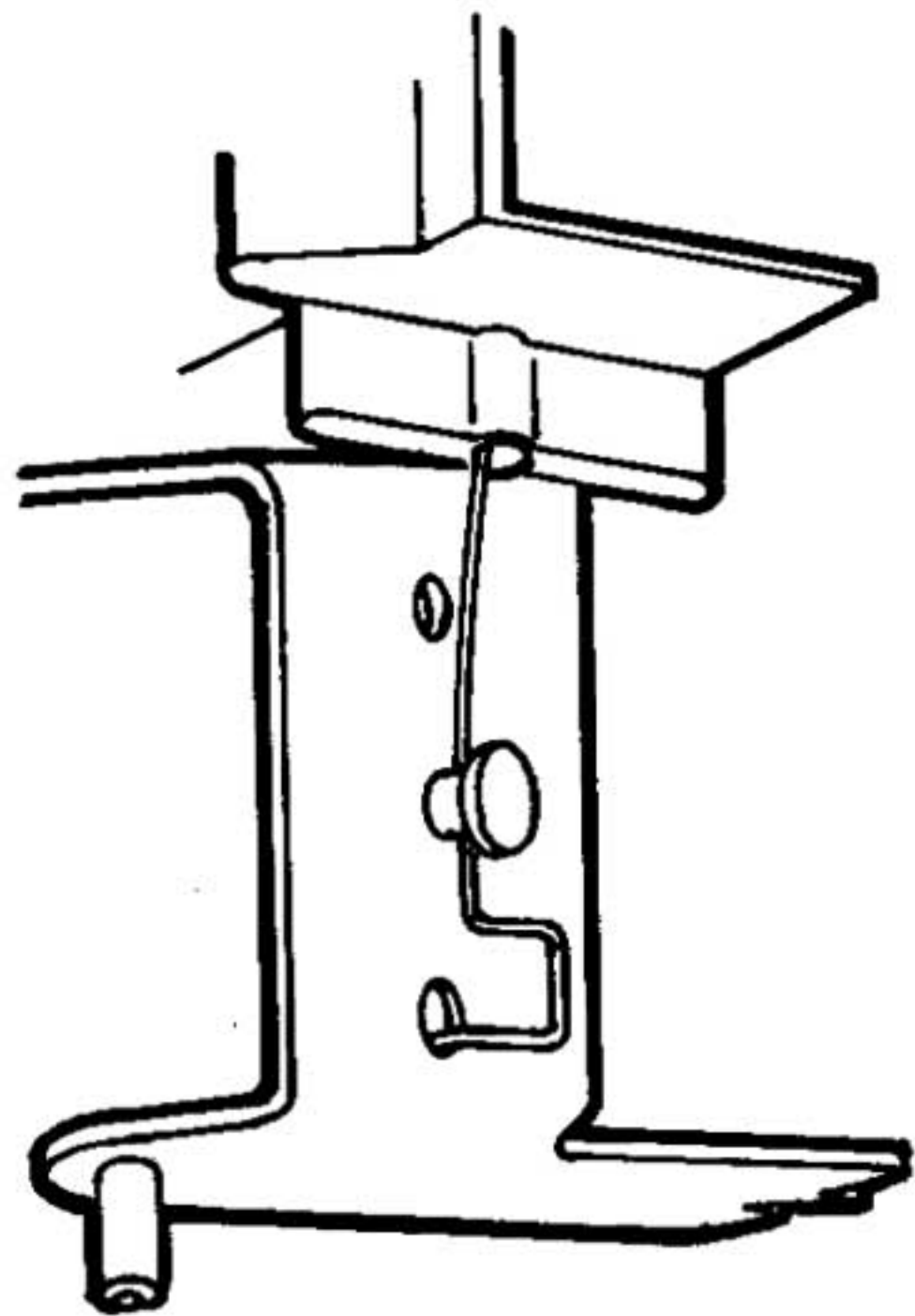

Pickup arm overload spring location
diagram 16

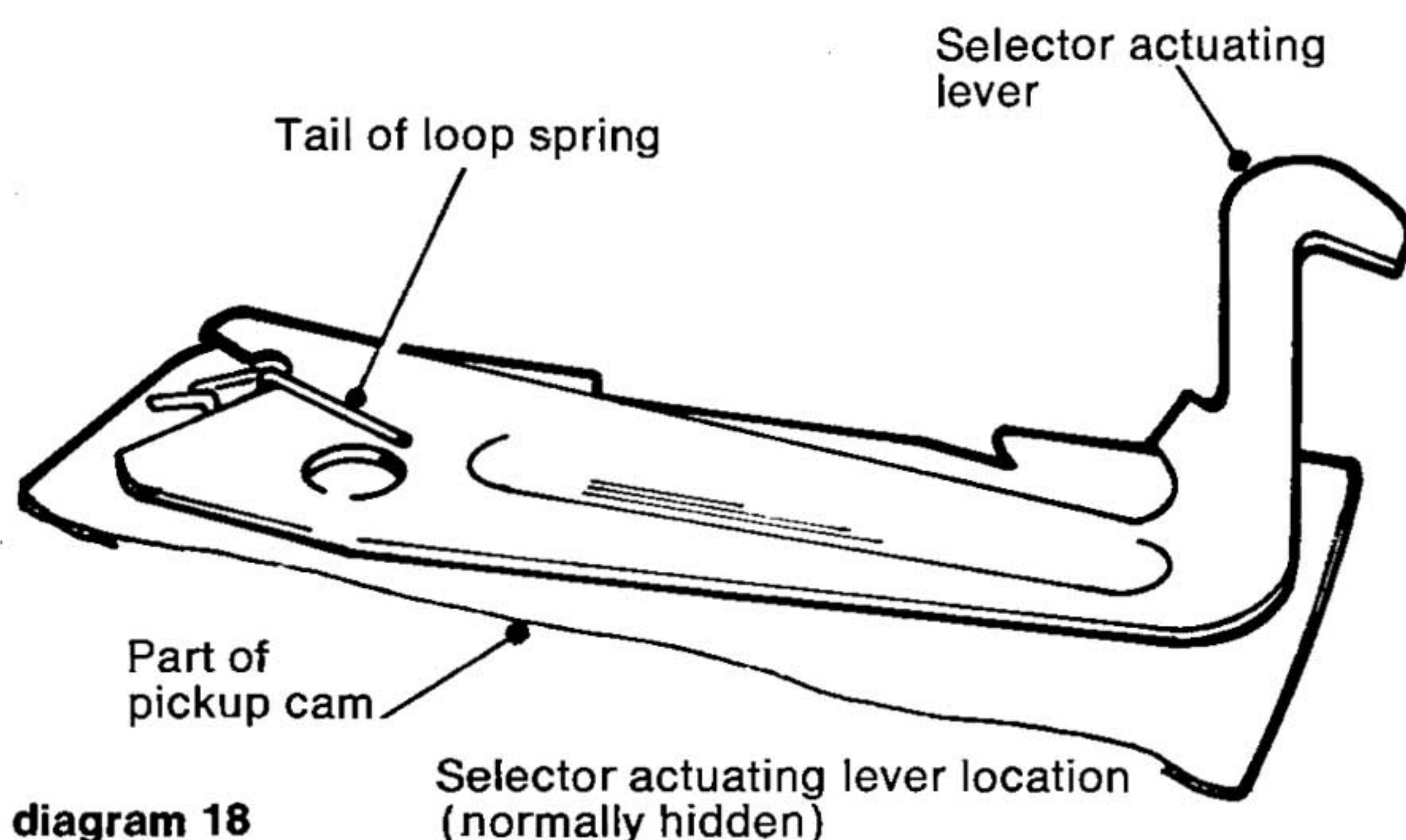

diagram 18

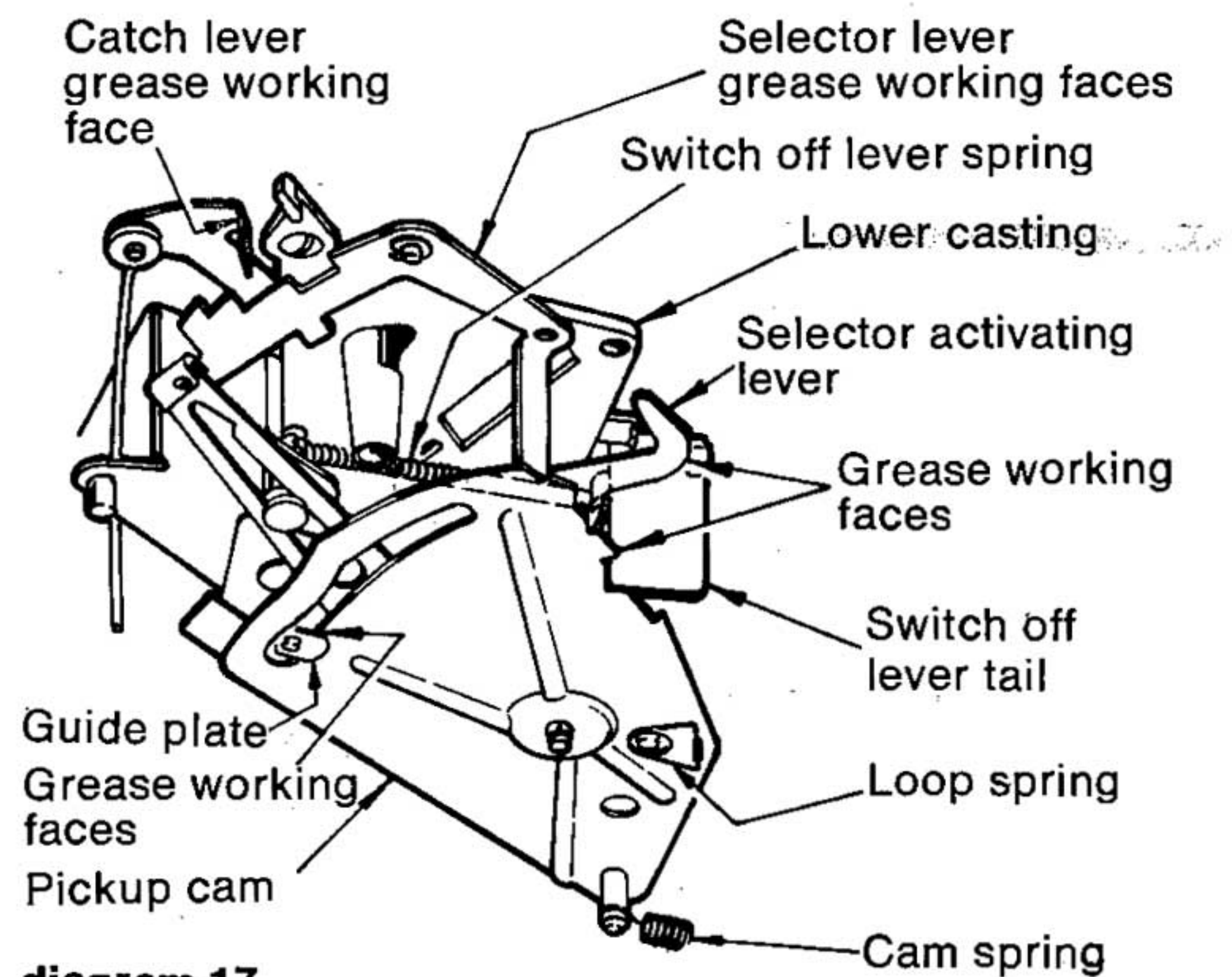

diagram 17

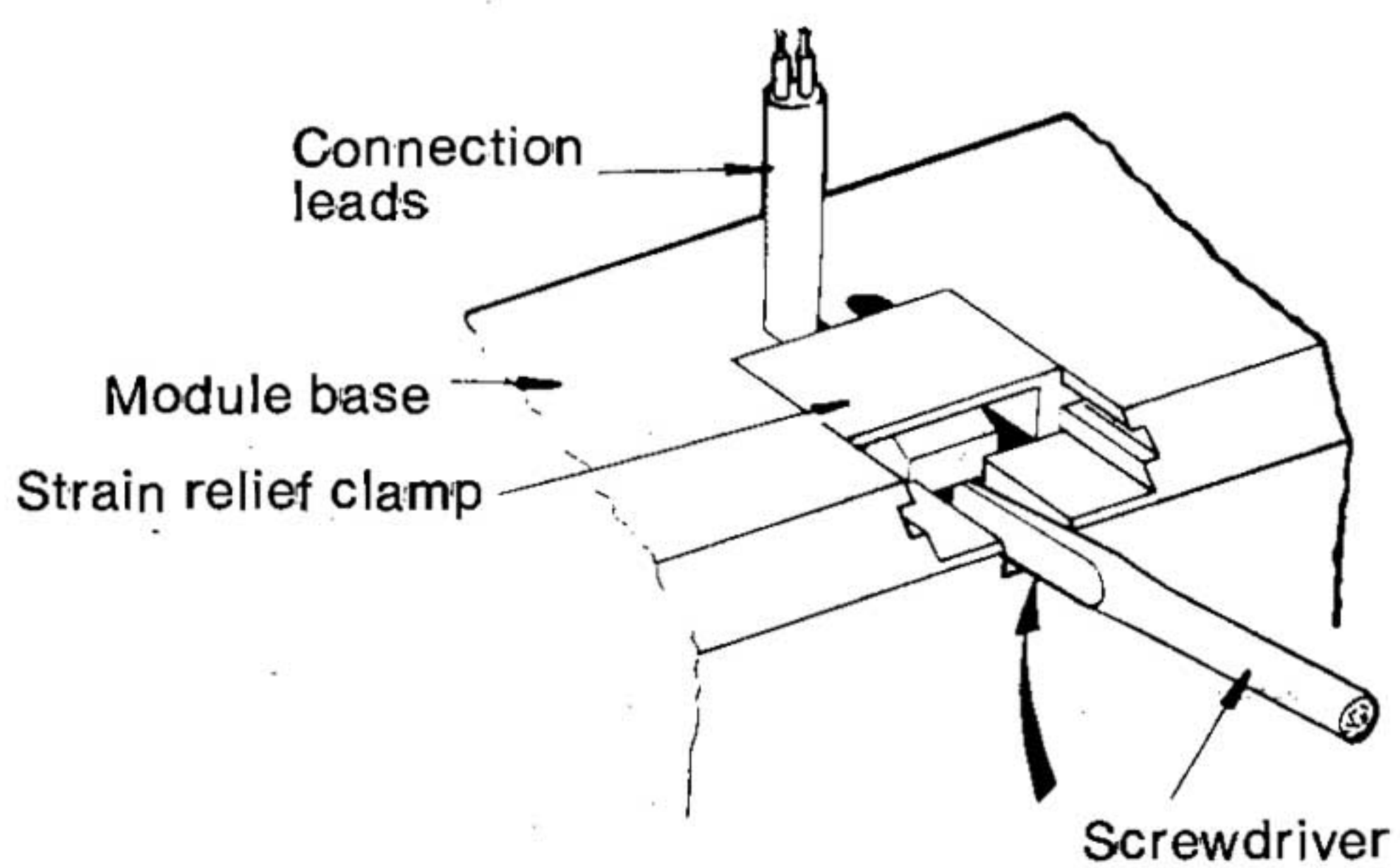

diagram 19

fault charts

The unit should be disconnected from its power supply and the stylus protected before making service adjustments. Numbers in brackets refer to the exploded view.

| Fault | Cause | Correction |
|---|--|--|
| TURNTABLE SPEED | | |
| (a) Turntable fails to start, runs slowly or at wrong speed when switched on. | 1 Oil or dirt on driving surfaces. | 1 Remove turntable (see 'Maintenance' section) and clean inside rim, periphery of intermediate wheel (94) and motor pulley (57). |
| | 2 Faulty intermediate wheel spring (88). | 2 Check that the spring is secured. Move operating control to 'Manual' – spring should stretch. If it does not, replace it. |
| | 3 Intermediate wheel support bracket (73) not free. | 3 Wheel (94) should engage motor pulley (57) firmly when switched on and retract when switched off. If not, lightly oil spindles of the speed change mechanism assembly or replace damaged parts. |
| | 4 No voltage or low voltage at motor (52). | 4 Remove loom plugs from motor, switch on and check wiring with voltmeter. If no power, check back to source outlet, looking for loose connections, faulty switch contacts etc. Voltage should not be lower than 110V if low range supply or 220V if high range. If a voltage changeover block is fitted, make sure the links are correctly set. |
| | 5 Faulty motor coil(s). | 5 Remove plugs from motor (52) to check continuity of coils with ohmmeter. Replace motor if necessary. |
| | 6 Bearings of motor (52) out of line. | 6 If rotor does not spin freely, tap the motor body with a small block of wood (e.g. screwdriver handle) to realign bearings. Use only thin oil on these bearings; thick oil will clog them. |
| | 7 Motor pulley (57) or intermediate wheel (94) height set incorrectly. | 7 See 'Service adjustments' speed section and diagram 14. Check that both motor pulley screws are tight. |
| | 8 Bearings not free. | 8 Check motor (52), intermediate wheel (94) and turntable bearings. Clean and lightly oil if necessary. See Lubrication section under 'Maintenance'. |
| | 9 Incorrect motor pulley (57). | 9 Remove turntable (see 'Maintenance') and check pulley is coded to suit power supply frequency. If incorrect change the pulley. See 'Speed' section under 'Service adjustments'. |
| (b) Turntable speed varies (wow and flutter). | 1 Various. | 1 See Fault (a), Causes and Corrections 1, 7 and 8. |
| | 2 Worn or oversize holes in records. | 2 In exaggerated cases, align the record concentrically on the turntable by hand. Avoid using records on a record changer whose mechanism may be wearing the record holes. |
| | 3 Damaged rotor shaft of motor (52). | 3 Replace motor (52). |
| | 4 Flats on driving surface of intermediate wheel (94). | 4 If running the unit for a few hours does not cure the fault, replace the wheel (94). Note: Do not switch the unit off from the power supply before it has stopped automatically, as the unretracted wheel (94) may form flats. |

| Fault | Cause | Correction |
|--------------------------------|---|---|
| PICKUP ARM MOVEMENT | | |
| (c) Pickup tracks incorrectly. | 1 Dust accumulated around stylus tip. | 1 Clean carefully. |
| | 2 Stylus force too low. | 2 Check that the force is not lower than that recommended for the cartridge. Adjust if necessary – see 'Pickup stylus force', page 6. |
| | 3 Bias compensator incorrectly set. | 3 Make sure that the bias compensator is set correctly to correspond to the stylus force applied. |
| | 4 Worn or wrong size of stylus tip radius. | 4 Replace stylus. |
| | 5 Pickup leads tight or trapped at rear of arm. | 5 Make sure leads are slack and check that they are not caught in or touching mechanism beneath the unit plate. |
| | 6 Groove guard on record (raised rim). | 6 If used in 'Auto' mode, the stylus may land too far out and slide down the slope of the raised rim on certain records, jumping the first playing grooves. Reset the pickup lowering position so that it lands further in (see under 'Service adjustments'). |
| | 7 Body of pickup cartridge touches record. | 7 Make sure any cartridge fixing screws are secure and that the slide is in position properly. |
| | 8 Counterbalance weight clamped off centre. | 8 Check that the weight (2) is clamped in an untwisted attitude. |
| | 9 Excessive friction in friction link (45). | 9 Apply a spot of thin oil inside slot. See diagram 20. |
| | 10 Automatic trip links not free. | 10 Move pickup inwards by hand checking for linkage fouling – trip pawl mechanism on main cam (151) and auto stop link (112). Reshape or replace as necessary. |
| | 11 Damaged pickup pivots or bearing (171), (12) and (22). | 11 Replace as necessary. |

| | | |
|---|---|---|
| (d) Pickup lands on record too far out and/or in, on 'Auto' play. | 1 Lowering position incorrectly set. | 1 See under 'Service adjustments'. |
| | 2 Tail of selector lever (41) or tail of catch lever attached to selector link (115), not square. | 2 Reshape. See diagram 17. |
| | 3 Friction link (45) requires lubrication. | 3 Apply a spot of thin oil inside slot. See diagram 20. |

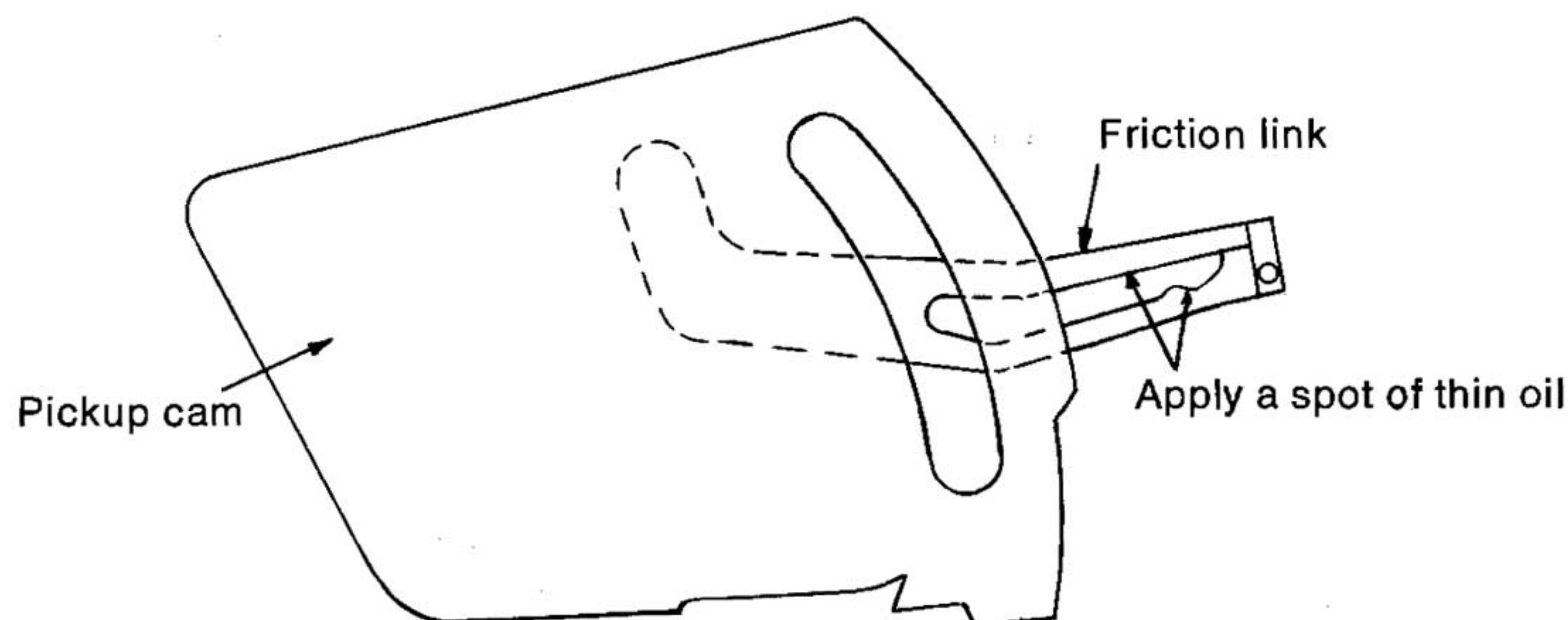

| Fault | Cause | Correction |
|--------------------------------|--|--|
| (e) Pickup arm fails to lower. | 1 Cueing lever (29) not lowered. | 1 Lower the cueing lever and check cueing height set correctly. |
| | 2 Lifting spindle mechanism (166 etc.) not free. | 2 With pickup arm raised slightly, lift the platform moulding at the top of the spindle. Although damped it should return slowly through pressure of spring (168). If not check for damage or restriction. Also check that lifting spring (47) has not slipped from its retaining shoulder on the spindle. See diagram 21. |
| | 3 Pickup arm pivots (22) and (171) not free. | 3 Remove the pivots and check them for damage. Replace them if necessary. |

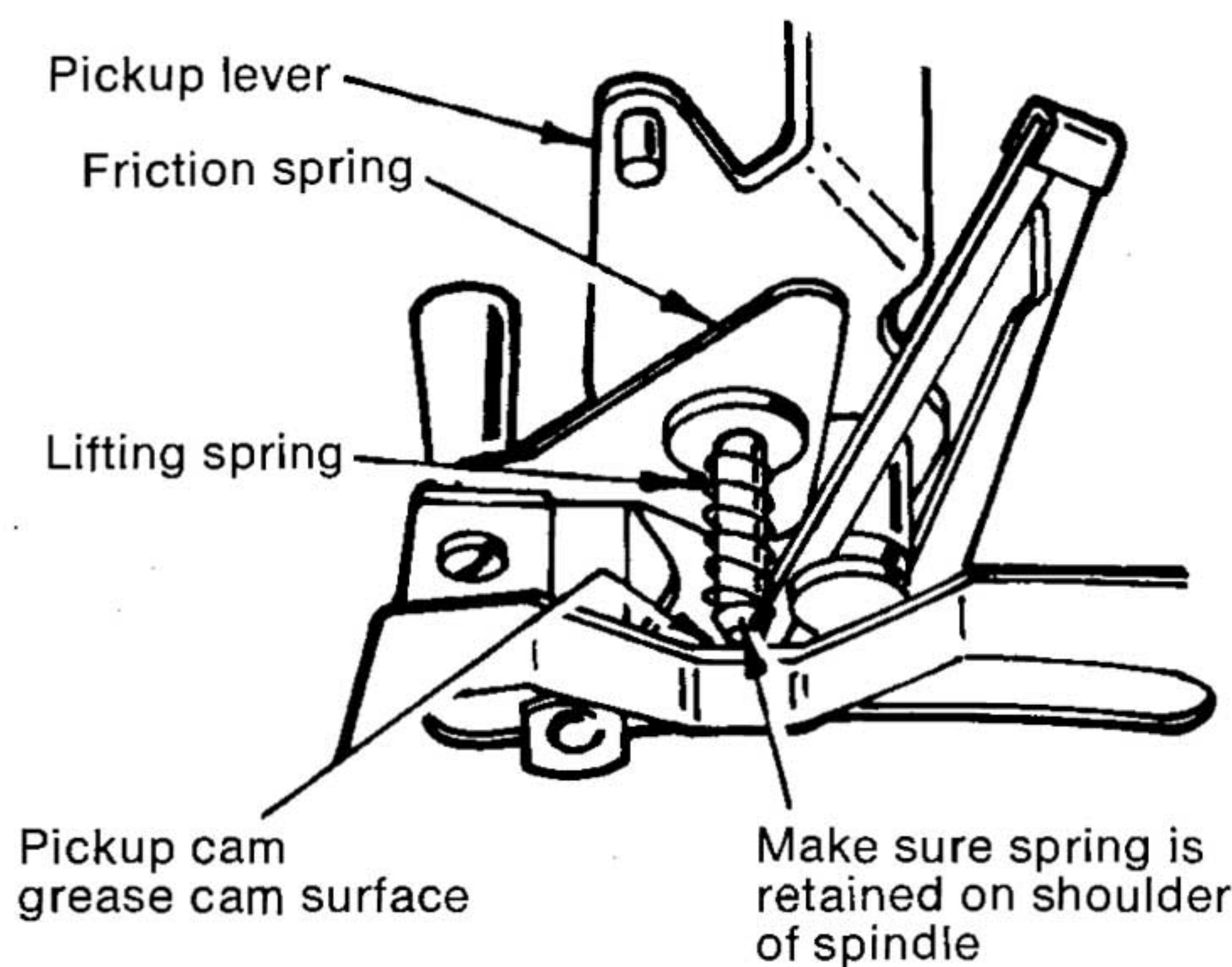

diagram 21

| | | |
|---|--|---|
| (f) Pickup begins to lower then swings in. | 1 Pickup leads tight or trapped. | 1 Slacken if necessary and see that they are not caught in mechanism beneath the unit plate. |
| | 2 On 'Auto' play, lifting spring (47) or friction spring (34) binding. | 2 Check that the lifting spring is secure and moves freely. With lifting spring held clear, deflect friction spring away from pickup cam (49); it should spring back when released. Replace damaged spring(s). See diagram 21. |
| (g) Pickup fails to lift and return at the end of the record. | 1 Various. | 1 See Fault (c), Causes and Corrections 1 to 5, 7, 8 and 9. Check that the lug on the trip pawl mounted on main cam (151) is square. Reshape it if necessary and make sure the trip pawl pivots freely. |
| | 2 Non-standard record. | 2 Reject record as instructed under 'Operating instructions'. |
| (h) Pickup lowers too quickly when cueing. | 1 Faulty fluid damping. | 1 First check that stylus force is correct. If the damping fluid fails to control the rate of descent of the pickup, see 'Damped cueing system' section under 'Maintenance'. |
| (i) Pickup lowers too slowly when cueing. | 1 Tight bearings or mechanism fouling. | 1 Make sure that the pickup arm pivots freely and that pickup leads or mechanism do not restrict its movement. Note that a descent time of up to several seconds is considered acceptable and is unlikely to be caused by excess damping fluid. |
| (j) Pickup wavers when lowered during cueing. | 1 Play in lowering mechanism. | 1 Make sure tension nut (144) is in its factory set position, keeping spring (143) in compression. The top of the nut should be $\frac{1}{16}$ in from the underside of the cast lug on pickup body (7). Also make sure that spring (168) is positioned so that its lower tail lodges against lifting platform (166) and its top tail pushes against the back of the boss on upper casting (26) thus preventing slack movement in the lifting platform. |
| | 2 Lowering platform too smooth. | 2 Rough up the underside of the platform rivetted to the top of pickup lever (44) with fine emery paper. |
| (k) Fails to 'reject'. | 1 Operating control (117) not moved correctly. | 1 The control must be switched to 'Auto', then immediately returned to 'Manual' or the record will replay. |
| (l) Fails to select, switches off. | 1 Interselector lever bent. | 1 Make sure tail of interselector lever on lower casting (32) makes appropriate contact with tail of switch lever (111). |

| Fault | Cause | Correction |
|---|---|--|
| NOISE | | |
| (k) Rumble, heard through speaker(s) whilst stylus is in blank record groove. | 1 Rumble on record. | 1 Check by playing other records, that a particular record is not at fault. |
| | 2 Lack of lubrication of drive mechanism. | 2 See 'Maintenance'. |
| | 3 Intermediate wheel (94) rubbing against side of motor pulley step (57). | 3 Check heights of wheel and pulley. See 'Speed' section under 'Service adjustments' and diagram 14. Make sure pulley screws are equally tight. |
| | 4 Driving surface of intermediate wheel (94) dirty, indented or hardened. | 4 Clean the wheel with a cloth or scrape its driving surface to remove dirt. If this and running the unit for a few hours does not help, replace the wheel (94). |
| | 5 Faulty installation. | 5 Check that the unit floats freely on its mounting springs (30) with damping pads (31) in place, that the motor (52) hangs freely in its rubber grommets (56) and that no part of the mechanism is in contact with the mounting board. |
| | 6 Worn or dirty turntable bearings. | 6 Clean cushion ring (134), thrust washers (135) and (137) and ball race (136). Oil the ball race and replace the thrust washers if worn or the rubber cushion ring if hardened. Make sure cushion ring (138) is positioned on the cast turntable boss. Check that thrust washers have dull, lapped faces to bearings. |
| (l) Interference heard as crackles etc. through speaker(s). | 1 Faulty contact in power supply circuit, pickup circuit or earth connections. | 1 Examine all leads and connections for damage and check screws for tightness, also push-on tags. If the switch is faulty, fit a new loom assembly (110). |
| (m) Electrical hum. | 1 Faulty earthing connections. | 1 Check the earthing system of the unit making sure that all connections are secure, both the unit plate, motor and earthing point connections and the pickup lead connections. Make sure the amplifier is properly earthed. |
| (n) No sound. | 1 Open circuit in pickup leads. | 1 Check the continuity of the pickup leads from the cartridge to the tag strip (disconnect the cartridge before making this test). Make sure push-on tags are firmly in position. |
| GENERAL | | |
| (o) Fails to switch off when record has played. | 1 Switch off lever on lower casting (32) controlled by spring (158), stiff or bent. | 1 Check that this lever (see diagram 17) moves freely and returns under control of its spring (158). Lightly grease between lever and unit plate if necessary. If tail of lever is bent out of square, reshape it. |
| | 2 Operating control lever (117) tight. | 2 Check operation of return spring (155) and grease sliding surfaces of control lever and unit plate. Lightly oil pivot of lever. |

A number of Garrard module bases and covers may be used with this series of units.

Some earlier units were fitted to the WB1 wood base with SPC1 plastic dust cover. Also available for earlier units were the larger WB5 base with SPC4 Mk II cover, this combination having the advantage of allowing the unit to play with the cover in place. The SPC series covers were of the non-hinged lift-off type.

The module base and cover illustrated on the front of this manual and by diagram 19 clamp details, is of the lift-off, hinged type with side-support leg. This type has been superseded by the BLC15 base and cover, illustrated here with Model 35SB. The BLC15 base and cover is a lift-off type with friction hinges and can be used with any unit in the Garrard 'Autoslim' and 'Unimech' series.

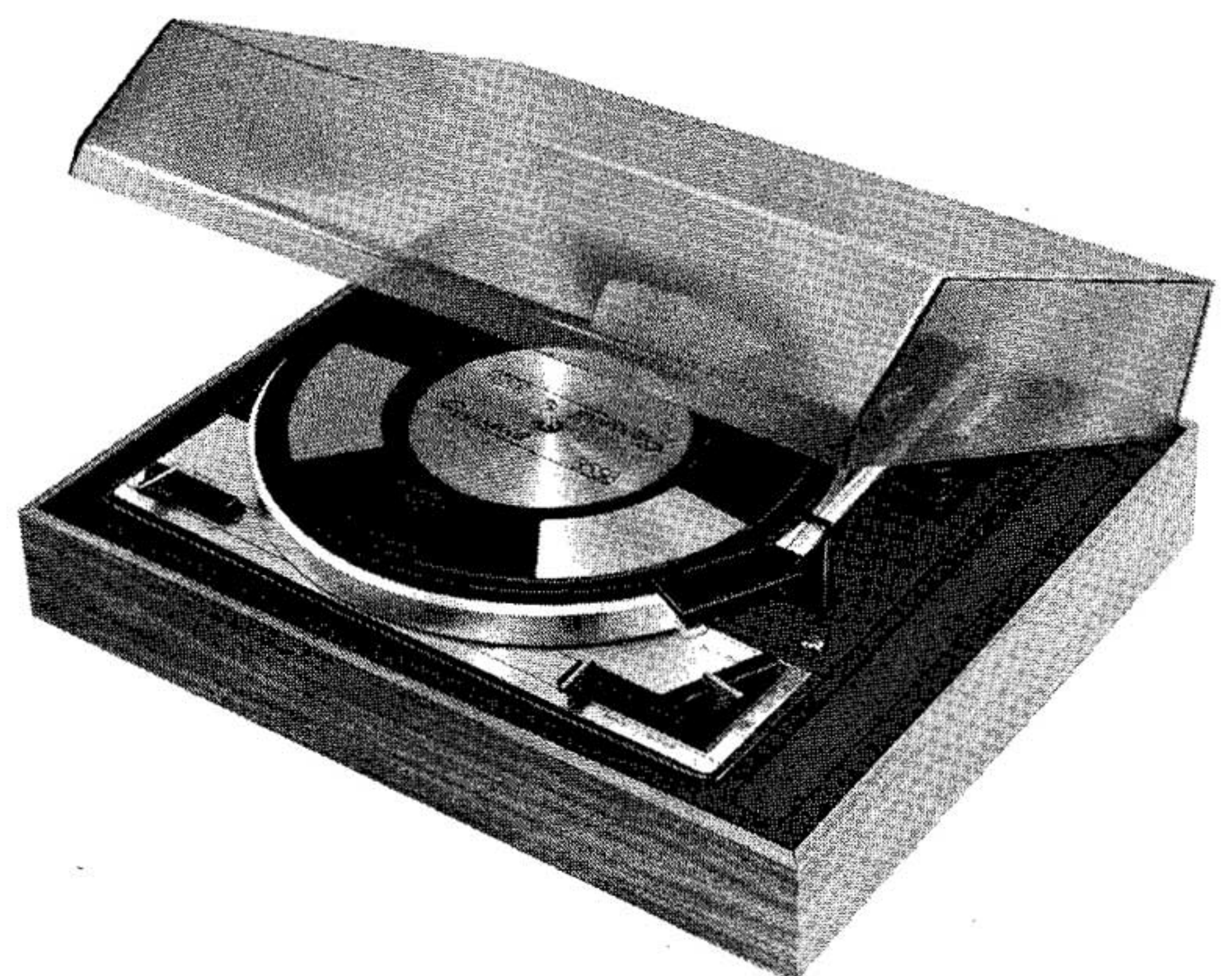

Garrard Engineering Limited
Newcastle Street
Swindon Wiltshire England
Telephone: Swindon (0793) 5381
Telex: 44271

Garrard 
A PLESSEY QUALITY PRODUCT

74750 Issue 4

designed + printed by the Borough Press Wiltshire Limited